



Design of the LAN Network of Hospital Comandante Manuel Piti Fajardo

Yunet Gasca Suárez^{1,*}, Omar Mar Cornelio²

¹Ministry of Public Health, La Habana, CUBA; yunetgasca@gmail.com; <https://orcid.org/0000-0002-6470-0247>

²University of Computer Sciences, Cuba; omarmar@uci.cu ; <https://orcid.org/0000-0002-0689-6341>

* Correspondence: yunetgasca@gmail.com

Abstract

The design of the network of a health institution is a complicated task due to all the aspects that it encompasses, to satisfy the consumption needs of digitized services, using minimal time and at the lowest possible cost. The Manuel Piti Fajardo Hospital, according to the scope of health services it provides, has a system for Hospital Management, the Galen Clinica. This system requires a well-structured network design, with the appropriate equipment that responds quickly and efficiently to the traffic generated in the network. In line with this objective, a cost-benefit study was carried out, after applying the LAN design methodology and calculating approximately the traffic generated on the network in the main departments of the hospital, whether it be the Matrix or the Unit. Surgical and Imaging. With this, the result was to locate the network backbone, and determine the network components that should be replaced according to the financial budget of the hospital, a better response to the requests made by users and according to the evolution of technologies. of information and communications.

Keywords: Backbone, network, services, system

1.Introduction

The Manuel Piti Fajardo Hospital is in charge of providing specialized assistance to the sick and injured in the different territories of the country, providing services in the specialties and modalities defined for the center. In order to facilitate and streamline these health services, the hospital has a communications network that guarantees communication between distant areas due to their location between its different blocks [1], [2]. Communications networks currently play a fundamental role in different health institutions, since they allow increasing their productivity thanks to the optimized circulation of information.

Having a computerized network in the hospital is due to the need to approach citizens with the health services that pay them more dynamically and efficiently, avoiding a greater accumulation of errors in the information that is handled, gaining in time and effectiveness towards the population [3], [4].

The hospital currently has a system (Galen Clinicas) that requires good organization and transmission speed in terms of connectivity. For this reason, the aim of this research is to design the Hospital's LAN network in order to detect whether it is performing well in terms of distribution of network components, topology, physical and logical locations.

2. LAN design methodology

For a LAN to be effective and meet user needs, it must be designed and implemented according to a planned series of systematic steps.

The information gathering process helps clarify and identify any current network problems. This information includes the history of the organization and its current state, projected growth, operational policies and management procedures, office systems and procedures, and the views of the people who will use the LANs [5], [6]. Therefore, a survey was carried out that collects certain information necessary to take as a starting point for the design of the LAN network.

Connectivity

Check and complete the following information about the structure of the communication network and the external connection of the hospital. (Take into account the form of connection (fiber optic or others) with the ISP of (ETECSA), use, link speed)

Type of connection with the ISP (ETECSA)

- Optical Fiber X
- Dial-up
- UTP
- Others, in this case specify

Connection speed

Download 10 Mb/s

Upload 8 Mb/s

Evaluate the stability of the connection: *Stable, with a latency of 132.8 ms*

Figure 1. Synthesis of the survey applied to the hospital

3. Selecting the Topology Type of the LAN network

It is decided to use the extended star topology as it uses the 802.3 Ethernet CSMA / CD technology.

4. OSI layer topology map

In the diagrams, each distributor has a code that corresponds to the following images. Each scheme corresponds to a Level of the building or surrounding area.

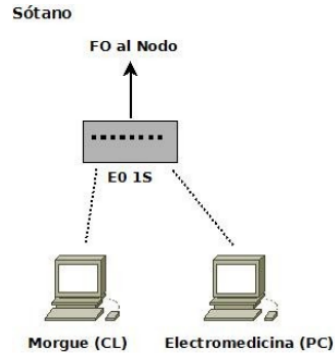

Figure 2.Hospital basement topology map

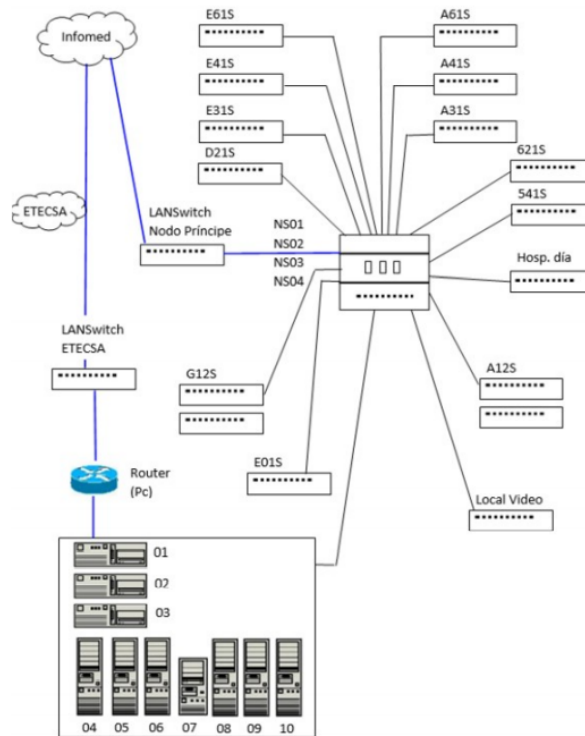

Figure 3.Communications node topology map

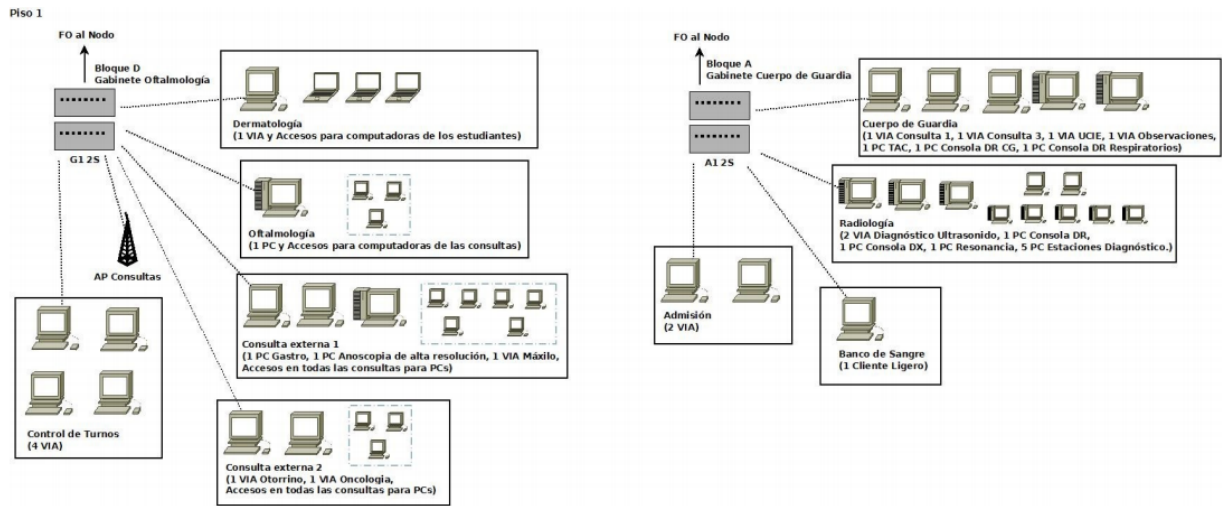

Figure 4.Hospital Floor 1 topology map

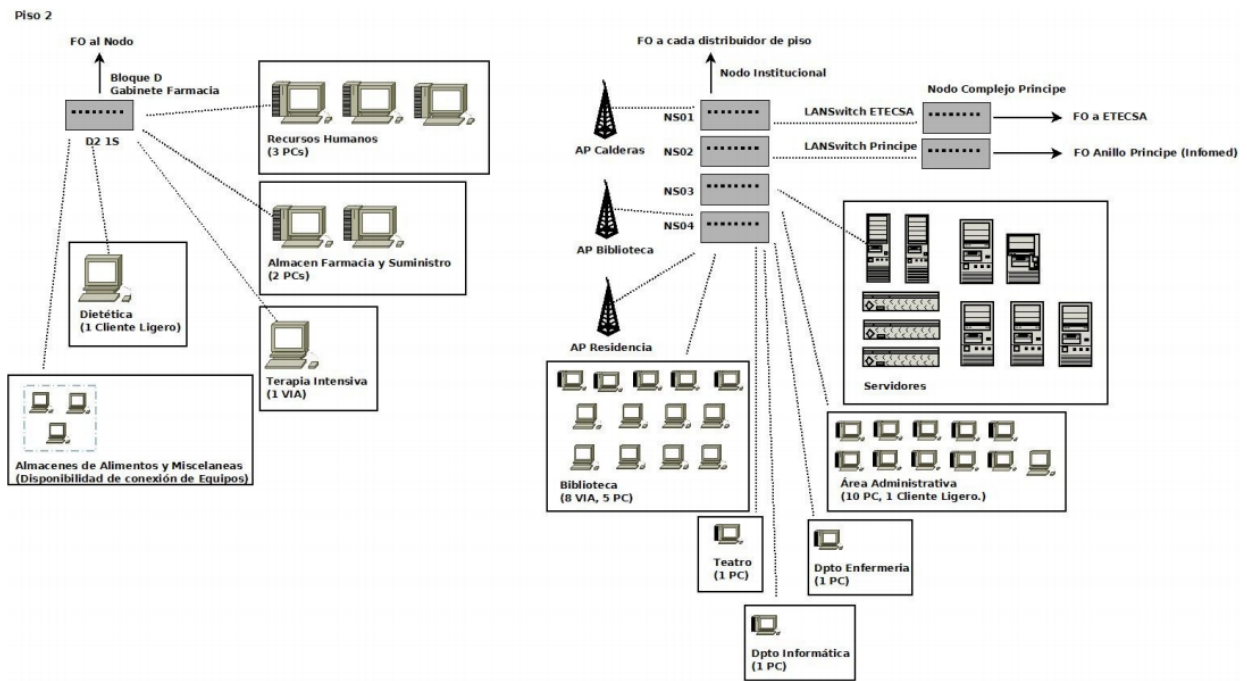

Figure 5.Hospital Floor 2 topology map

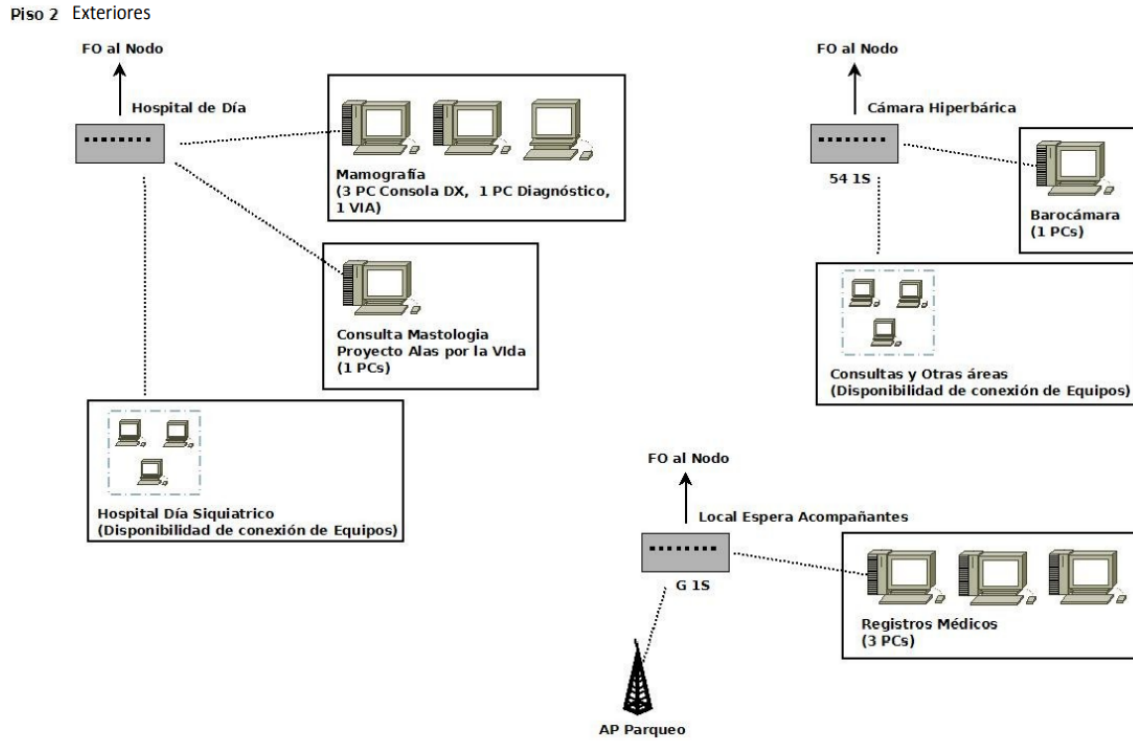

Figure 6. Hospital Exterior Floor 2 topology map

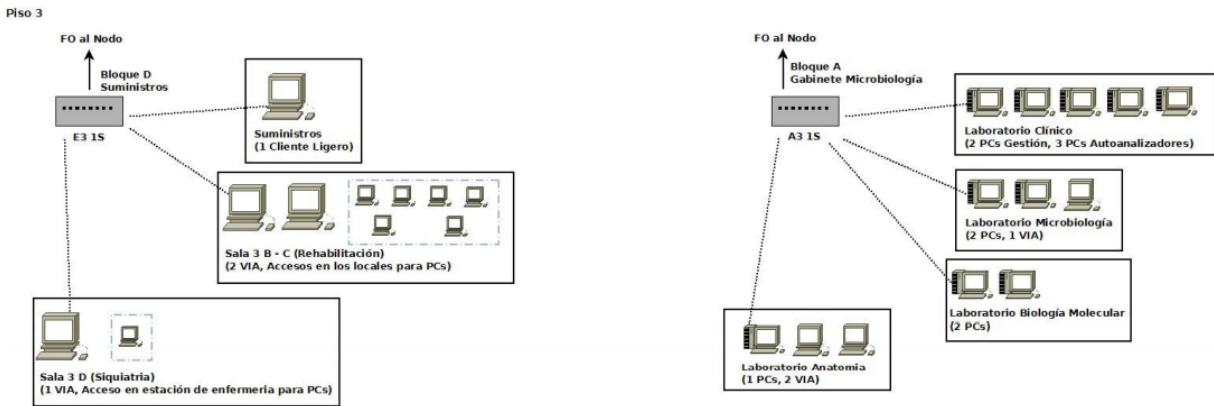

Figure 7. Hospital Floor 3 topology map

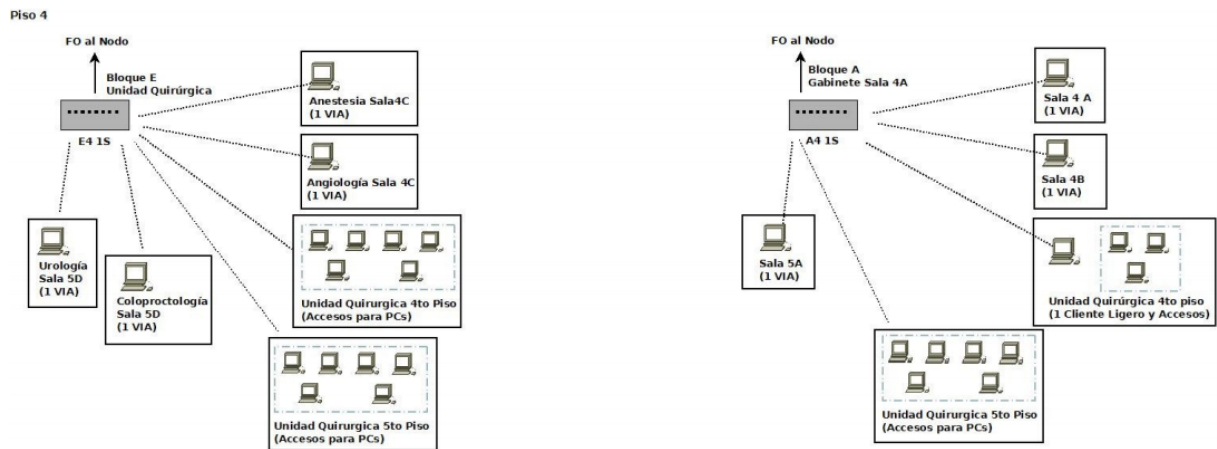

Figure 8. Hospital Floor 4 topology map

5. Work Model

The Client-Server model is used due to the hospital's need to connect the services provided by each server to several clients. A key example is the case of the Galen Clinics system installed and in operation in said institution, due to the great need that the services according to the different modules can be consumed by dissimilar users simultaneously.

6. Operating systems

Network Operating Systems are those systems that keep two or more computers together through some means of communication (physical or not), with the primary objective of being able to share the different hardware and software resources. The most widely used network operating systems are: Novell Netware, LAN Manager, Windows Server, UNIX, Linux, LANtastic, Li. [7]

Just as a computer cannot work without an operating system, a network of computers cannot function without a network operating system. If you do not have any equipment that mounts a network operating system, there will not be a centralized management of resources, so the network will become what we have called a work group.

Three of the existing servers in the hospital have Windows Server 2000 as a system and the remaining and not least GNU / Linux. With the update of this network it is intended to improve the existing services and increase the network's capacity to provide remote support services, file sharing, netmeeting, video conferencing, nephrology and oncology, payment of services, virtual banking, in addition to the possibility of increasing new services in the future without major changes in the network.

➤ It was decided to use Windows Server due to:

The most common services provided by this type of Operating System for network management are the following:

1. Resource sharing services: This service makes it possible to make files, folders, printers, or any other resource available to network users, centrally and with a security level determined and decided by the administrators of these services.
2. Security: Like most major network operating systems, Windows Server provides security for any resource on the network. The Windows network server maintains all records from user accounts and management to

user rights and permissions. To access any resource on the network, the user must have the necessary rights to perform the task and the appropriate permissions to use the resource.

3. **Print Services:** On a Windows Server network, any server or client can act as a print server. The difference is that if the print service is mounted on a client, the network administrator will not have full control over it. The normal thing is to install these services on the server and manage them from this computer.
4. **Network services:** Windows Server provides different network services that help with the overall management of a network environment. Some of these services are:
 - **Messenger Service.** Monitor the network and receive pop-up messages for the user. Alarm service. Sends the notifications received by the messaging service.
 - **Exploration service.** Provides a list of servers available in domains and in workgroups.
 - **Station service.** It runs on a workstation and is responsible for the connections to the server. Server service. Provides network access to resources on a computer.
5. **Interoperability:** The different network protocols and services managed by a Windows Server system are used to configure a mixed or easily interoperable network environment. As an example, the NWLink network protocol designed to make Windows Server compatible with other non-Windows servers, such as Novell NetWare, is incorporated.

➤ **It was decided to use GNU / Linux due to:**

It is made up of a central team and multiple terminals for users. This operating system includes network capabilities, designed specifically for large networks, but also features some applications for personal computers. UNIX / Linux works well on a standalone computer and, as a consequence of its multitasking capabilities, it also works well in a network environment.

7. LAN Network Design

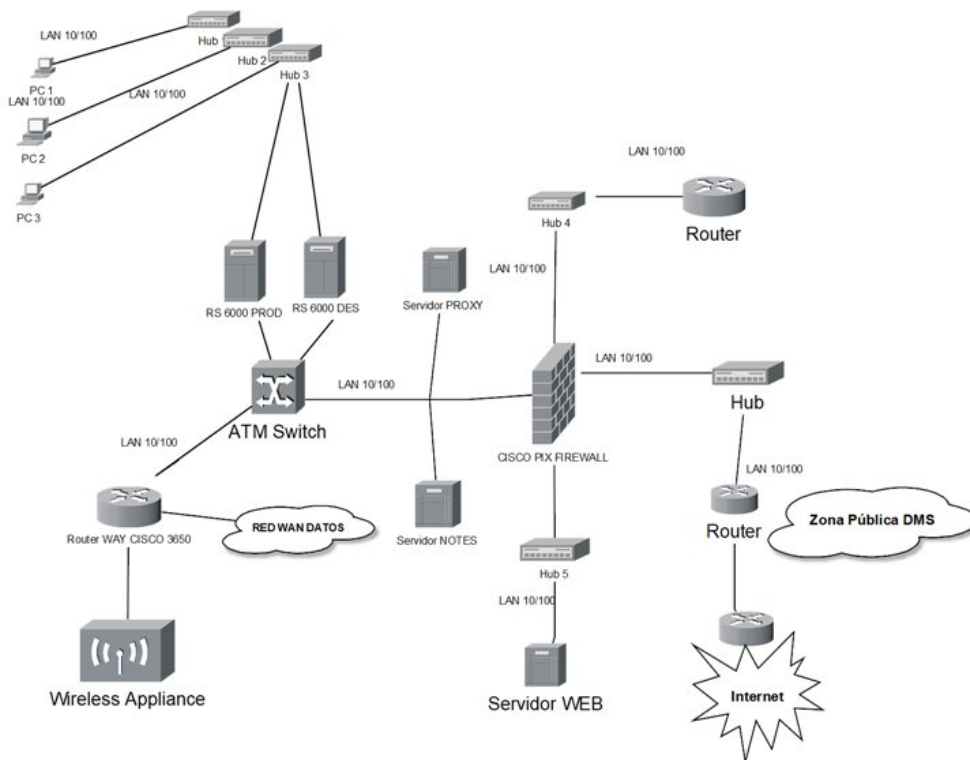

Figure 10. Design of the Main LAN Network of the Hospital Matrix

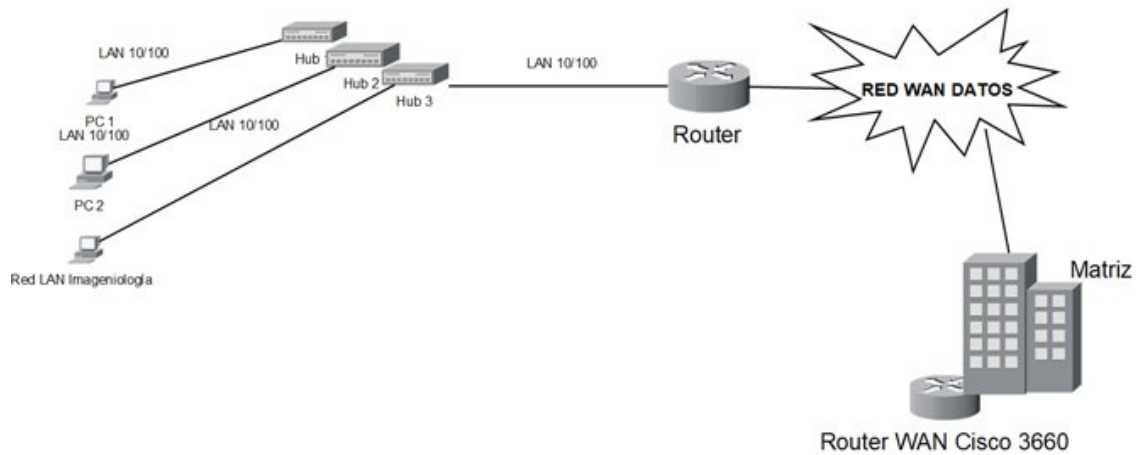

Figure 11. Design of the LAN Network of the Hospital Imaging Area

Table 1. Existing equipment on the LAN

Name	Networked PCs	HUB				Router
		Quantity	Mark	Model	Port	
Matrix	3	6	3 COM	3C17653	8	4
ImagingArea	2	3	IBM	73P2323	16	2

According to the Headquarters Department and 3 departments with health services in order to the population, it is considered that they are the ones with the highest data traffic load. Because of this they have been included in a backbone network to form the backbone of the new network.

Traffic sizing: To size the traffic generated by each department, will be dimensioned:

- Traffic per workstation
- Voice traffic
- Video traffic

For the sizing of traffic per workstation, downlink traffic will be taken into account, that is, the traffic that each station receives, since the uplink values are lower because the applications to be used are based on a client architecture -server in which the workstations demand data and services from the server that provides them, the incoming information (downlink) to the workstation being greater than the outgoing (uplink) [8], [9].

Web Traffic (Tw): To measure the average web traffic generated by each workstation, measurements are made, obtaining as a result that each user opens an average of 7 web pages in an hour, with an average size of 100 KBytes each; In addition, each user downloads files with an average of 4 MBytes in an hour, resulting in:

E-mail traffic (Te): To measure the average traffic of the email service generated by each workstation, statistics are taken, in which it is obtained as a result that each user receives an average of 10 e-mails in an hour, with an average size of 500 KBytes each.

Traffic for file transfer to other agencies (Ta): To measure the average traffic of the file transfer service generated by each workstation, statistics are taken, obtaining as a result that each user receives an average of 4 MBytes per hour.

Traffic for access to the Database (Tb): To measure the average access traffic to the database generated by each workstation, the statistics show that each user performs an average of 20 transactions in an hour, with a average size of 200 KBytes each.

Traffic for file transfer to other agencies (Ta): To measure the average traffic of the file transfer service generated by each workstation, statistics are taken, obtaining as a result that each user receives in average 4 MBytes per hour.

Traffic for access to the Database (Tb): To measure the average access traffic to the database generated by each workstation, the statistics show that each user performs an average of 20 transactions in an hour, with a average size of 200 KBytes each [10].

Table 2. Calculation of current traffic per workstation

Application	Traffic by Work Station
Web Traffic	21,76
Email	11,11
File transfer	9,1
Databases	8,89

Table 3. Calculation of the traffic generation for the desparments

Department	Number of Seasons of work	Traffic generated by station	Traffic Video	Traffic Voice	Generated traffic for the departments
Matrix	170	35,93	1000	768	48,75
Imaging	18	35,93	1000	768	14,95
Surgical Unit	14	35,93	1000	768	14,06

8. Gigabit Ethernet

Justification for the use of Gigabit Ethernet: Gigabit Ethernet is an improved evolution of Ethernet technology. The use of level 3 IP switches (network level), together with a correct sizing of the backbone network, makes it possible to guarantee not only the sending of data and multimedia traffic, but also of voice (VoIP, Voice over IP). As advantages, we can highlight the flexibility of reconfiguration, the scalability from 10 Mbps to 10 Gbps, its simplicity of installation, management and maintenance and the low cost of implementation. The management and Voice and data traffic monitoring can be done from the same application if IP is used for voice transmission (VoIP)[11].

9. Media types

In the LAN part, category 5 UTP cable is currently installed that must be supported, in addition to possible new installations it must support category 5e and 6 UTP cable. Regarding the WAN links, the equipment must allow

interconnection through 9/10 um single-mode fiber optic, working in the second window (1300 um) and must have an available gain of 10.2 dB minimum, as calculated in equation 3.5.

10. Ports 10/100Base TX

They are the ports that will be connected to the switches in each of the department LAN networks; Based on the number of stations in each department, 20 10/100 BASE-TX ports are needed, using sensing, half / full duplex, with an RJ-45 connector [12].

11. Costs for the installation of Fiber Optic

It is assumed that there is a working group for the installation of the optical fiber and a working group for the installation of the equipment. The installation time of the fiber optic cable is the time necessary for the import procedures of the equipment. The installation of ducted single-mode fiber optic cable is required in the wavelength range 1280 to 1350 nm whose geometric, mechanical and transmission characteristics are in accordance with the ITU - T - G.652 recommendation. Coming up next to demonstrate the referential costs of this facility, these data are hypothetical [13], [14].

Table 4. Cost for sections between departments

Stretch	Distance	Referential Cost (CUP)
Matrix-Imaging	2	240000
Matrix- Surgical Unit	4	588000
Surgical Unit-Imaging	0,5	124800
Total		952800

It is intended to replace the existing hubs with a more advanced technology, which is that of switches.

Table 5. Description of the selected switch

Description	Quantity	Price Unitary (CUP)	Total Amount (CUP)
Switch Catalyst 4507R with: Double card controller. 24 interfaces 10/100/1000 BT-2 Interfaces 1000 Base LX.2 interfaces 100 Base LX	5	468000	2340000

12. Conclusions

Ethernet networks are one of the most widely used technologies, considerably influencing further technological development for any health institution.

The steps of the LAN design methodology were applied where the extended star topology was selected as it uses CSMA / CD technology, which will guarantee that, if the medium is being used, the station will have to wait and otherwise it will be able to transmit.

With the development of the OSI Layer Topology Map, it was possible to understand how the network components and workstations are distributed by floors in the hospital, for a new relocation if necessary. The selection of a working model in this case the Client-Server guaranteed the exploitation of one of the most important systems currently for the National Health System, the Galen Clinicas, due to the large number of services to be consumed by users. Counting in the institution with the use of Windows Server 2000 and GNU / Linux network operating systems allowed sharing the hardware and software resources described above, in order to provide better performance and response times to the requests made by users of health for the population. Developing the calculation of network traffic guaranteed an optimal selection regarding the use of Gigabit Ethernet technology in order to guarantee the transmission not only of data but of voice, voice over voice and video. The analysis of the cost of the sections between the main departments led to the replacement of hubs by switches, which is a faster and more advanced technology.

References

- [1] A. Bahri, and S. Chamberland, "On the wireless local area network design problem with performance guarantees," *Computer Networks*, vol. 48, no. 6, pp. 856-866, 2005.
- [2] V. T. Raisinghani, and S. Iyer, "Cross-layer design optimizations in wireless protocol stacks," *Computer communications*, vol. 27, no. 8, pp. 720-724, 2004.
- [3] M. Gen, A. Kumar, and J. R. Kim, "Recent network design techniques using evolutionary algorithms," *International Journal of Production Economics*, vol. 98, no. 2, pp. 251-261, 2005.
- [4] L. Zhang, L. Yang, Z. Wang, and D. Yan, "Sports wearable device design and health data monitoring based on wireless internet of things," *Microprocessors and Microsystems*, pp. 103423, 2020.
- [5] A. M. S. Ramírez, and O. M. Cornelio, "PROPUESTA METODOLÓGICA E IMPLEMENTACIÓN DE UNA RED LAN PARA EL INSTITUTO DE MEDICINA DEPORTIVA," *UNESUM-Ciencias. Revista Científica Multidisciplinaria. ISSN 2602-8166*, vol. 5, no. 4, pp. 169-184, 2021.
- [6] O. Mar, G. G. I. Ching, and B. Bron "Remote Laboratory System for Automatic Engineering," *International Journal of Wireless and Ad Hoc Communication*, vol. 1, no. 2, pp. 55-63, 2020.
- [7] L. Rainie, and B. W. , "Networked. The New Social Operating System," 9780262017190, 2012.
- [8] O. Mar Cornelio, J. Gulín González, and I. Santana Ching, "Sistema de Laboratorios Remoto para las prácticas de control de la carrera de Ingeniería en Automática," *Revista Cubana de Ciencias Informáticas*, vol. 15, no. 2, pp. 77-95, 2021.
- [9] M. Lan, Y. Zhang, L. Zhang, and B. Du, "Global context based automatic road segmentation via dilated convolutional neural network," *Information Sciences*, vol. 535, pp. 156-171, 2020.
- [10] M. F. Carrión Morales, *DESIGN OF THE COMMUNICATIONS NETWORK OF THE PICHINCHA MUTUALIST FOR THE CITY OF QUITO BASED ON HIGH SPEED ETHERNET TECHNOLOGIES*, Pichincha, 2006.
- [11] R. Breyer, *Switched, Fast, and Gigabit Ethernet*, 2012.
- [12] C. S. Inc, *Cisco Connected Grid Ethernet Switch Module Interface Card Getting Started Guide*, 2014.
- [13] V. V. Kumar, M. Devi, P. V. Raja, P. Kanmani, V. Priya, S. Sudhakar, and K. Sujatha, "Design of peer-to-peer protocol with sensible and secure IoT communication for future internet architecture," *Microprocessors and Microsystems*, vol. 78, pp. 103216, 2020.
- [14] Z. Masood, R. Samar, and M. A. Z. Raja, "Design of a mathematical model for the Stuxnet virus in a network of critical control infrastructure," *Computers & Security*, vol. 87, pp. 101565, 2019.