



## Survey on Smart Cane For Visually Impaired Using IOT

Sonia Jenifer Rayen<sup>1,\*</sup>

<sup>1</sup>Associate Professor, Department of Computer Science and Engineering,  
Jeppiaar Institute of Technology, India

Email: [soniya@jeppiaarinstitute.org](mailto:soniya@jeppiaarinstitute.org)

### Abstract

This fundamental point of this task to give a voice-based route framework for the outwardly tested voice acknowledgment module and it is planned to give in general estimates object discovery and constant help through Worldwide Situating Framework (GPS) and ultrasonic sensors. This venture focuses on the advancement of an Electronic Voyaging Help (Estimated time of arrival) unit to assist the visually impaired individuals with finding an impediment free way. This Estimated time of arrival is fixed to the stick of the outwardly tested. At the point when the item is distinguished close to the stick of the outwardly hindered it cautions them with the assistance of the vibratory circuit. The outwardly tested will give the objective's name as the contribution to the voice acknowledgment module. GPS module persistently gets the scope and longitude of the current area. GPS contrasts it and the objective's scope and longitude. The outwardly tested gets the articulated headings which he wants to follow to arrive at his objective

**Keywords:** Global Positioning System; Electronic Travelling Aid; Navigation System; Latitude and Longitude

### 1. Introduction

Visual shortcoming can confine people's ability to perform conventional tasks and can impact their own fulfillment and ability to associate with the incorporating scene. Visual inadequacy, the most outrageous sort of visual deterrent, can reduce people's ability to perform step by step tasks, and move about free. Incredible quality recuperation grants people with different levels of visual impedance to totally profit from life, achieve their destinations and be dynamic and beneficial in the current society. Copious undertakings have been made to help the outwardly disabled by upgrading and further developing progressions.

By the presentation of an essential sensor, the arrangements to the guide of visually impaired individuals have surprisingly expanded. Numerous colleges and organizations like IBM have given a piece of their concentration to the advancement of help for visually impaired individuals. A portion of the prominent ones is keen sticks and impediment sensors.

Late improvement incorporates self-driving autos and shrewd glasses. Over the most recent 30 years, different steps that have been created are the content or discourse programming and cell phone applications. Also, the frameworks that are being created on mechanical technology and man-made reasoning will be exceptionally beneficial to them too.

One of the main considerations in building up these specialized guides is the similarity with the client. He ought not to experience difficulty getting to know the item. The highlights of the item ought not to be too hard to even think about using. Indeed, even the warning frameworks used to alarm the visually impaired ought to be agreeable and solid.

Another fundamental thought is the cost of such things. Since they are presently paying for drugs or other nursing cares, the expense of the thing should be in the reach that is reasonable. One more component of these things should be the robustness. The customers most likely will not in all likelihood charge the system. Hence, a reasonable measure should be taken for it.

To help outwardly impeded and to give a reduced and complete arrangement, a savvy stick can be created which will incorporate a GPS framework, obstruction discovery component and a sound module, with the goal that the stick can educate the headings to the client. The hindrance recognition system is joined with route and area identification utilizing GPS-GSM and a sound module with Bluetooth handset to give a superior arrangement than the effectively existing arrangements.

The developments we plan to use are sonar advancement, GPS course, GSM arranges, voice affirmation and cautioning. Sonar development is used for check acknowledgment. The norm of the structure works in the way that the pointer sends and gets a sign. Upon the social affair of the sign, the not set in stone to use the time it took for the sign to reflect back. It is a direct system that works with the properties of electromagnetic waves. This is transcendently used to find eliminates in various fields. Obstacle acknowledgment is done by ultrasonic sensors associated with the stick. The sensors are picked to satisfy their standards of sensor point, partition, and various boundaries. Right when the sensors run over some obstacle, it sets off a voice assertion from the plan of announcements viably recorded, as demonstrated by their semantics and alerts the person about the obstruction in the manner. In order to decrease the commotion and sound dispersal, an earpiece is added to give the sound announcements. The GPS system is used to distinguish the current region and makes the customer show up at the objective by proclaiming the current region name whenever needed by the customer and sign from up to 65 GPS satellites and moving them into the specific position and timing information that can be examined either UART port or RS232 consecutive port. Low control use is needed for the little size and best in class GPS helpfulness. Both the LVTTTL-level and RS232 signal interface are accessible on the interface connector and a stock voltage of 3.6V~6.0V is reinforced. The keen GPS getting wire module is available as an off-the-rack section which is 100% attempted. The splendid GPS getting wire module can be presented for OEM applications. In like manner, the getting wire can be tuned to the last structure conditions.

## **2. Related Work**

Harsha Gawari and Prof. Meeta Bakuli [1], presents the design and execution of a framework that will help in the route of the outwardly weakened individuals, in which GPS and voice acknowledgment alongside snag shirking to control outwardly hindered. This framework manages the outwardly disabled individual by issues the order and a similar time the scope and longitude estimations of the client are gotten ceaselessly from the GPS collector and the bearings are constantly given to the client with the assistance of sound sign. The proposed framework contains the equipment like MICROCONTROLLER (ARM LPC2148 which depends on 32/16 bit ARM7TDMI-S CPU with constant imitating and inserted follow support), GPS RECEIVER (GPS recipients, to give three dimensional area scope, longitude, and elevation), VOICE

RECOGNITION (Different tasks are performed at various levels on the information sign, for example, Pre-accentuation, Framing, Windowing, Mel Cepstrum investigation and Recognition), IC HM2007 and the programming projects like Embedded C, Keil IDE and Uc-Flash. Mrunal Pawar et al. [2] present the route framework which gives direction to grounds route and hindrance location also for visually impaired individuals. This proposed framework aides visually impaired individuals to reach from source to goal with the briefest way and dependent on the idea of GPS. Ultrasonic sensors are utilized deterrent shirking for its developments and android gadget and Bluetooth for notice, the microcontroller of 8051 families is utilized to accomplish the ideal tasks. The ultrasonic sensor is attached to the stick of outwardly debilitated people, sends the ultrasonic waves continually whenever the contraction is going on the best way the ultrasonic sensor. Exactly when hindrance comes before it, the ultrasonic waves are reflected again from an article and that information is passed to the microcontroller and microcontroller controls the motors left, great, back and front ward on the ultrasonic sign. K. Ramarethinam, Mrs. K. Thenkumari and P. Kalaiselvan [3] present a versatile framework with an independent component that enables the visually impaired individuals to go through the well-known and new condition. The proposed framework comprises of equipment like GPS collector (PD321 GPS module is utilized to get 10 satellite sign for progressively exact), ARM Cortex-M3 processor (32-piece processor for exceptionally deterministic constant applications), Sonar sensor (SRF02 a solitary transducer ultrasonic rangefinder in a little impression PCB), Temperature sensor (MCP9800 is an advanced temperature sensor equipped for perusing temperatures), A simple to-computerized converter (contracted ADC, A/D

or A to D), and programming resembles LPCXpresso is another, minimal effort improvement stage accessible from NXP

### 3. Methodology

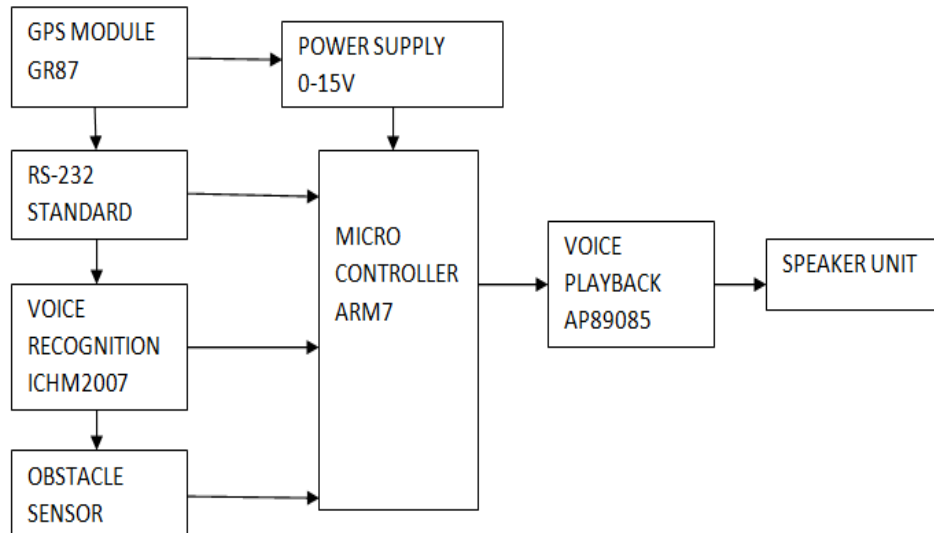

Figure .1 Architecture of Proposed System

The square chart of the rule board shows up in Figure. In this framework, the 32-piece ARM processor (LPC2148) is used, which is the center of this endeavor. The LPC2148 microcontrollers rely upon a 16-piece/32bit ARM7TDMI-S computer chip with consistent emulating and introduced follow support, that unite microcontroller with embedded quick streak memory going from 32 kB to 512 kB.

A 128-piece wide memory interface and novel reviving specialist designing engage 32- piece code execution at the most outrageous clock rate. For essential code size applications, the elective 16-piece Thumb mode lessens code by more than 30 % with insignificant execution penalty. GPS beneficiary is used to get the current region as longitude and degree. The GPS used here is GR87. The yield of GPS beneficiary is given to the processor using successive correspondence. In this system, yield is as voice from now on speaker/headphones are used. GPS GR87 is a significantly organized sharp GPS module with GPS fix radio wire that is imaginative. The gathering device is related with the module through the LNA. The module has 51 stations getting engine and 14 station track engine, which is good for tolerating sign from up to 65 GPS satellites and moving them into the specific position and timing information that can be examined either UART port or RS232 successive port. Low control usage is needed for the little size and best in class GPS handiness. Both the LVTTTL-level and RS232 signal interface are accessible on the interface connector and a stockpile voltage of 3.6V~6.0V is maintained. The clever GPS radio wire module is open as an off-the-rack fragment which is 100% attempted. The astute GPS gathering mechanical assembly module can be presented for OEM applications. Similarly, the gathering mechanical assembly can be tuned to the last structure conditions.

### 4. Hardware Description

#### 4.1 Microcontroller

The Controller utilized will be ARM LPC2148 which depends on 32/16 bit ARM7TDMI-S CPU with ongoing copying and implanted follow bolster that joins the microcontroller with inserted rapid glimmer memory going from 32 kB to 512 kB. It has numerous significant highlights like. 16/32-piece ARM7 microcontroller in a minor bundle.

It has on-chip static RAM and on-chip blaze program memory. It offers continuous investigating and fast following of guidance execution.

The highlights of LPC2148 are

- USB 2.0 Full Speed agreeable Device Controller.
- 10 piece A/D converters.
- Multiple sequential interfaces with two UARTs.
- Low cost, low utilization, simply taking care of and adaptability.

These highlights make the controller solid for the task.

#### **4.2 GPS Receiver**

Global Positioning System (GPS) satellites communicate signals from space which are utilized by GPS recipients, to give three-dimensional area (scope, longitude, and height) and exact time. Solid situating, route and timing administrations are given by the GPS recipients to clients all around the globe persistently in all climate, day or night, anyplace on or close to the Earth. The GPS collector utilized in this undertaking is GR87.

Its fundamental highlights are

- On-chip 1Mb SRAM
- Low control utilization
- Multi-way alleviation equipment
- Reacquisition time 0.1 seconds

#### **4.3 Voice Recognition**

A talk assessment is done after the customer talks in a beneficiary and information sources are therefore taken. The control of the information sound sign is done at the system level. Different exercises are performed at different levels on the data sign, for instance, Preemphasis, Outlining, Windowing, Mel Cepstrum examination and Acknowledgment (Coordinating) of the verbally communicated word. The talk affirmation structure contains two perceived stages. The first is an educational gathering, while, the resulting one is implied as a movement meeting or testing stage. During the getting ready stage, the speaker needs to give trial of their talk to set up the system. During the affirmation stage, the speaker needs to give trial of his talk to organize with the current data set and gives cautious match. The voice affirmation IC used here is IC HM2007.

### **5. Conclusion**

The world's biggest number of visually impaired individuals and India's present populace is over 1.22 billion. A prior dominant part of outwardly impeded individuals like to not utilize electronic guides, and utilize just sticks or guide hounds. The fundamental purposes behind this incorporate the moderately staggering expenses and generally

poor degrees of client fulfillment related to existing electronic frameworks. So we attempted to build up an easy and easy to understand framework for visually impaired individuals with the most noteworthy conceivable exactness. This procedure offers innovative courses of action to displace the ordinary strategies for coordinating apparently debilitated people. Similarly, it might be viably associated wherever where it can manage spots like a mall, plane terminals, etc. In this endeavor, we have used an ARM processor that contains more memory and its functioning speed is high. We oversee or investigate the outwardly hindered people using voice.

**References**

- [1] Harsha Gawari and Prof. Meeta Bakuli, "Voice and GPS Based Navigation System for Visually Impaired", *International Journal of Engineering Trends and Technology (IJETT)*, Volume 11, Number 6, May 2014, pp.296-299.
- [2] Mrunal Pawar, Minal Pawar and Rohit Najawan, "Route Finding Application for Blind People", *International Journal of Engineering Development and Research (IJEDR)*, Volume 4, Issue 2, 2016, pp. 144-147.
- [3] K. Ramarethinam, Mrs K. Thenkumari and P.Kalaiselvan, "Navigation System for Blind People Using GPS & GSM Techniques", *International Journal of Advanced Research in Electrical, Electronics and Instrumentation Engineering (IJIREEIE)*, Vol. 3, Special Issue 2, April 2014, pp. 398405.
- [4] Anushree Harsur and Chitra.M, "Voice Based Navigation System for Blind People Using Ultrasonic Sensor", *International Journal on Recent and Innovation Trends in Computing and Communication (IJRITCC)*, Volume: 3 Issue: 6, June 2015, pp. 4117 – 4122.
- [5] V.D.Ambeth Kumar, Dr.M.Ramakrishnan, V.D.Ashok Kumar and Dr.S.Malathi (2015) "Performance Improvement using an Automation System for Recognition of Multiple Parametric Features based on Human Footprint" for the *International Journal of kuwait journal of science & engineering*, Vol 42, No 1 (2015), pp:109-132
- [6] T Ramya, S Malathi, GR Pratheeksha, VDA Kumar, " Personalized authentication procedure for restricted web service access in mobile phones", *Fifth International Conference on the Applications of Digital Information and Web Technologies (ICADIWT 2014)* (DOI: 10.1109/ICADIWT.2014.6814702)
- [7] VDA Kumar, D Elangovan, G Gokul, JP Samuel, VDA Kumar, " Wireless sensing system for the welfare of sewer labourers", *Healthcare technology letters* 5 (4), 107-112. DOI: 10.1049/htl.2017.0017
- [8] Kumar, V.D.A., Sharmila, S., Kumar, A. et al. A novel solution for finding postpartum haemorrhage using fuzzy neural techniques. *Neural Comput & Applic* (2021). <https://doi.org/10.1007/s00521-020-05683-z>
- [9] Ambeth Kumar V.D., Ramakrishan M. (2011) Footprint Based Recognition System. In: Das V.V., Thomas G., Lumban Gaol F. (eds) *Information Technology and Mobile Communication. AIM 2011. Communications in Computer and Information Science*, vol 147. Springer, Berlin, Heidelberg. [https://doi.org/10.1007/978-3-642-20573-6\\_63](https://doi.org/10.1007/978-3-642-20573-6_63).
- [10] M. Anitha, V. D. Ambeth Kumar, S. Malathi, V. D. Ashok Kumar, M. Ramakrishnan, Abhishek Kumar, and Rashid Ali, " A survey on the usage of pattern recognition and image analysis methods for the lifestyle improvement on low vision and visually impaired people", *Pattern Recognition and Image Analysis* Journal and will be published in Issue 1, Vol. 31, 2021