



New Model of Sustainable Supply Chain Finance Based on Blockchain Technology

Muzafer Saracevic^{1,*}, Nan Wang², Elma Elfic Zukorlic³ and Suad Becirovic³

¹ Department of Computer Sciences, University of Novi Pazar, Serbia

² Jilin University of Finance and Economics, Changchun 130117, China

³ International University of Novi Pazar, Novi Pazar, Serbia

Emails: muzafers@uninp.edu.rs, ctuwangnan@126.com,
g.menadzer@uninp.edu.rs, s.becirovic@uninp.edu.rs

Abstract

Blockchain technology has received more and more attention from all walks of life and has also been sought after by the market and financial institutions. More and more financial institutions and Internet companies have begun to participate in the research of blockchain technology. The application scenarios are also constantly expanding, and the landing in the financial field is the focus of all social concerns. This article takes Agricultural Bank as an example, analyzes its current advantages and disadvantages in using blockchain technology, and proposes policy recommendations based on this to provide a reference for joint-stock commercial banks to better use blockchain technology to improve business performance. Based on the theoretical analysis, this article studies the use of blockchain technology by joint-stock commercial banks, and selects Agricultural Bank, which has a well-developed financial technology in joint-stock commercial banks, as a case study. From the operating background of the agricultural bank and the cross-border payment and settlement business, the background begins with the agricultural bank's own business practices in blockchain technology and the traditional cross-border business and the innovative development of agricultural bank's blockchain technology, and then the application of event analysis to the application effects of agricultural bank's blockchain technology analysis. This paper analyzes the SWOT-PEST of the agricultural bank's use of blockchain technology, combined with the theoretical analysis of blockchain technology in this article, comprehensively analyzes the agricultural bank's use of blockchain technology in four aspects: policy, economy, society, and technology. Strengths, weaknesses, opportunities, and challenges. Through analysis, we can have a comprehensive view on the application of blockchain technology by Agricultural Bank, and based on this, we can summarize the problems that Agricultural Bank may have in applying blockchain technology. Through the analysis of the blockchain, we can see that the growth rate of agricultural bank's net profit was higher in 2013 and 2014. Finally, the article puts forward suggestions for the development of agricultural bank under the blockchain technology.

Keywords: Blockchain Technology, Sustainable Supply Chain, Financial Innovation, Agricultural Bank, Event Analysis Method, SWOT-PEST Analysis Method

1. Introduction

In China, the internal and external environment facing commercial banks is becoming more and more complicated. In the past few years, China has experienced a series of changes in the financial environment, including the liberalization of deposit interest rate ceilings, the approval of private banks, and the tightening of Internet financial regulations. With many competitors from other non-financial industries such as the Internet industry, China's commercial banks are facing huge challenges under the environment and competitive pressures [1]. Commercial banks are facing changes and there are many ways to change, but it is undeniable that embracing fintech and allowing fintech to enter commercial banks is a very efficient method [2]. If the blockchain technology enters commercial banks, there will be significant breakthroughs in cross-border payments, bills, and settlement, which can effectively control credit risk, save costs, and promote the orderly development of commercial banks. Contributions to transformation and development [3].

From the perspective of traditional finance, commercial banks are financial intermediaries. This article explains the value of blockchain and the role that blockchain technology plays in the change and development of commercial banks from the perspective of financial intermediation [4]. The application of blockchain technology to commercial banks can reduce information asymmetry, reduce transaction uncertainty, and reduce transaction costs [5]. There are many current researches on blockchain, but not much research on the combination of blockchain and commercial banks. Therefore, the research in this article extends the theory of financial intermediation and also helps to enrich the theory of the financial system [6]. At present, the development of financial disintermediation and Internet finance has caused a great impact on commercial banks. This article studies the use of blockchain technology in commercial banks and explores a joint-stock commercial bank in China based on the case of national joint-stock commercial banks. The path of change and development is conducive to enriching the relevant theories on the development of China's commercial banks.

Valentina Gatteschi proposed that Bitcoin is a decentralized digital currency that does not rely on banks or any other central authority to issue coins or verify transactions. Bitcoin is currently experiencing tremendous success, driven by a huge interest in users, politics, and speculation. A real currency can serve as a medium of exchange, a store of value, and a unit of account, but Bitcoin is largely unable to meet these criteria. Bitcoin has achieved only a small amount of consumer transactions. For a small number of merchants who accept Bitcoin, the average daily transaction volume of Bitcoin is far less than one transaction. Its volatility is much higher than that of widely used currencies, which brings huge short-term risks to users [7]. Kim mentioned that while microbanks have become possible through SMS or USSD messages in some places, their security flaws and session-based nature have prevented them from gaining wider adoption. Cryptocurrencies at the global level are able to achieve low-cost, secure, and universal transfer of funds between distributed peers, but their ability to reach more people in remote communities is still limited. They propose to take advantage of the delay-tolerant nature of the blockchain to provide banking services to remote communities that can only intermittently connect to the wider Internet [8]. With base stations providing connectivity in the local area, regular transactions are handled only by blockchain miners. Only when the connection is available will banks join to process currency exchange requests, reward miners, and track user balances. By distributing validation and storage tasks between nodes, our system design saves overall deployment and operational costs. The concept of blockchain technology and its potential to disrupt the banking world by promoting global remittances, smart contracts, automated bank ledger and digital assets. In this regard, Jong-Hyouk Lee starts with a brief overview of the core aspects of the technology and the development based on second-generation contracts. On this basis, Jong-Hyouk Lee discussed the key issues that must be considered when developing such ledger-based technologies in the banking context. Bitcoin not only implements a central bank-free financial instrument because of its novelty, but also as an alternative to solving classic distributed computing problems, such as reaching distributed agreements in front of misbehaving parties, and many other application

contracts, Reputation system, name service, etc [9]. However, the soundness and security of these applications depends on a thorough understanding of the basic properties of the underlying blockchain data structure, and all parties ("miners") generate "POW" (aka "password puzzle") by generating). In the Christian Sillaber speech, people started to gradually develop the basic attributes of the blockchain, and then showed how to build applications such as consensus and powerful public transaction ledger on top of these attributes. In recent years, the European payment market has undergone rapid changes due to changes in payment habits, new business rules, new legal frameworks and regulations. The emergence of new technologies and payment solutions has also completely changed the payment landscape in Europe [10]. Singh discussed basic issues such as the replacement of cash and non-cash payment instruments, payment costs, cost economics, and cash and deposit requirements. They also analyzed issues such as bilateral markets, commercial platforms, and critical quality issues[11]. Other chapters focus on new phenomena in the payment field, such as mobile payments, multilateral platforms, e-wallets, virtual currencies, decentralized ledger, private digital currencies, blockchain and instant payments

This article uses the SWOT-PEST analysis of blockchain technology, combines SWOT analysis and PEST analysis to analyze all aspects of the use of blockchain technology by joint-stock commercial banks. The advantages, disadvantages, opportunities and challenges are respectively divided into four aspects. Conduct policy, economic, social, and technical analysis. Sixteen combinations are required to achieve a comprehensive analysis. This chapter concludes with a summary of possible problems in the use of blockchain technology by China Merchants Bank.

2. Propose Method

2.1 Definition and Structure of Blockchain

The blockchain is composed of many nodes. In a blockchain network, each node includes a distributed network, P2P network transmission[12], cryptographic technology, smart contracts, consensus algorithms, etc. in the block chain. In order to simplify the development process of blockchain applications, some companies have developed a blockchain system architecture that provides blockchain-related network, storage, consensus, and encryption services. The need for secondary development can achieve the combination of the blockchain network and the application field[13]. The levels of the blockchain system architecture are mainly divided into data layer, network layer, consensus layer, incentive layer, contract layer and application layer.

Bitcoin is the most typical and successful application of blockchain, and it is a distributed storage public ledger of electronic money[14]. The typical representatives of the blockchain 2.0 and 3.0 are Ethereum (Ethereum) and Hyperledger Fabric (a sub-project of the super ledger) and some tokens or token chains derived from Bitcoin. For example: Primecoin, Peercoin, Ripple, etc. Its main feature is the introduction of a smart contract (chaincode) that can be automatically executed in the blockchain network environment. Through the independence and impartiality of smart contracts, solve the problem of mutual trust between customers and customers, and improve transaction execution efficiency without relying on third parties[15]. The blockchain-based certificate system belongs to the application of the blockchain 3.0 level. The basic architecture of the blockchain 3.0 level is shown in Figure 1.

Application layer		Electronic money	Programmable finance	Programmable domain
Contract layer	Programming language	Script	Solidity	Go
	Container technology		EVM	Docker
Container technology		Pow	Pow/pos	Practical Byzantine fault tolerance
Layer		Ghost	Ghost	
Network layer		TCP-based P2P	TCP-based P2P	HTTP
Data layer	Data structure	Chain structure	Chain structure	Chain structure
	Block storage	File storage	LevelDB	File system

Figure 1. Basic Frame Diagram

A major area of blockchain business is the connection of cryptocurrencies to traditional banks and financial markets. Venture capital-backed Ripple Labs is leveraging blockchain technology to reshape the banking ecosystem and allow traditional financial institutions to conduct their own businesses more efficiently [16]. Ripple's payment network enables banks to transfer funds and foreign exchange transactions directly between themselves without a third-party intermediary, which is now required by regional banks to transfer funds bilaterally to other regional banks without going through intermediaries. Ripple has also developed a smart contract platform and programming language, Godius. Another potential symbiotic relationship between traditional banking and Bitcoin is a Bitcoin technology invested in Cofffein by the Spanish bank Bunkter's Innovation Fund [17], whose purpose is to make it possible for end users to purchase directly without communication And sell Bitcoin. Other businesses also link Bitcoin to traditional financial and payment market solutions.

2.2 Data Layer

The data layer of the blockchain provides data storage services. Its main function is to organize and combine the various forms of data at the bottom to form a single block.

(1) Data block

Blocks are mainly used to store transaction data, and their size will change according to the differences in the system architecture of the blockchain and the number of transactions. The block mainly contains the number of bytes occupied by the number of transactions, the number of transactions, and multiple transaction data. The block data memory map is shown in Figure 2.

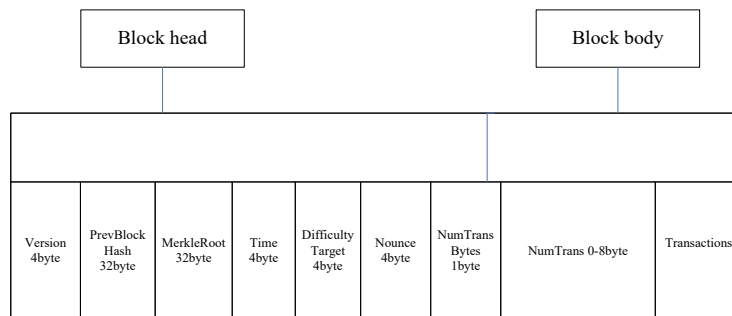

Figure 2. Block Data Memory Map

In the process of block storage, the bookkeeping node stores the transaction verification within a certain period and stores it in a block body of a block. Each block is connected in series according to the value of

prevBlockHash, and a complete sequence is formed in accordance with the time sequence Ordered chain structure. The new block is allowed to be added to the previous blockchain after passing the verification and reaching consensus across the network. Figure 3 is a schematic diagram of a blockchain chain structure.

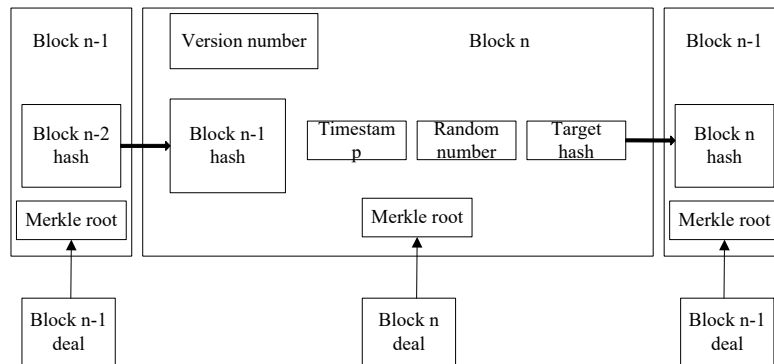

Figure 3. Blockchain Chain Structure Diagram

(1) *Timestamp*

The main function of timestamps is to calculate the total number of seconds to the current time according to Greenwich mean time [18], and provide an electronic evidence to prove that the current event is triggered at the same time in the world.

(2) *Hash Functions*

The hash function performs special operations on any length of input value to generate a fixed length of unpredictable hash value. If the input content is different, even if the difference between the two input values is very small, different hash values will be generated [19]. At present, it is not possible to get the input value through the result by backtracking or hash collision. The algorithm used in this paper is SHA-256.

(3) *Merkle Tree*

As shown in figure 4merkle tree structure, data1, date2, data3 and date4 are four pieces of data information saved on the blockchain. First, hash each data to get four hash values H1, H2, H3 and H4, then connect H1 and H2 to form a new data, then hash to get a hash value H12, and then connect H3 and H4 to form a new number Then hash to get the hash value H34. Finally, connect H12 and H34 to form a new data. Then hash to get the hash value h1234. H1234 is the last node, which is the root node of Merkle tree. In the process of data integrity verification, only comparing the root value h1234 of Merkle tree can know whether the data is consistent.

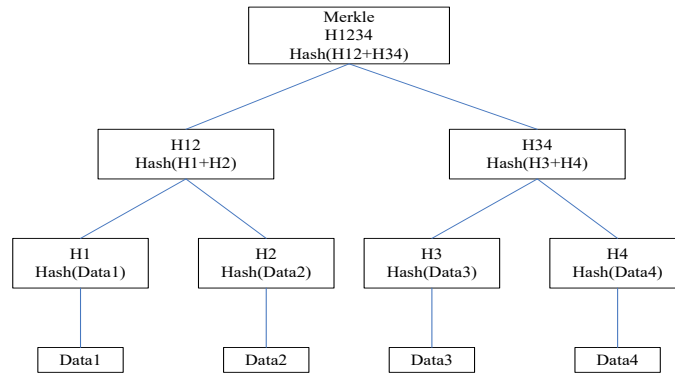

Figure 4. Merkle Tree Structure

2.3 Data Encryption

Both the sender and the receiver of the data have the key, which will increase the number of keys. When the number of users increases, it will bring the burden of key management. The common symmetric encryption algorithms are des algorithm and RC5 algorithm. Asymmetric encryption algorithm has two keys, the public key is the public key, and the non-public key is the private key. When it is necessary to send data to the receiver, the receiver only needs to show its own public key, and then the sender encrypts the data with the public key of the other party. The encrypted data received by the receiver is encrypted with its own public key, and only needs to use its own private key to decrypt the data. In the process of using asymmetric encryption to transmit data, once the data uses the public key to generate the ciphertext, only the corresponding private key owner can decrypt the data, which greatly guarantees the security of the data and the key. The commonly used asymmetric encryption algorithms include RSA and ECC (elliptic curve encryption algorithm). ECC encryption algorithm provides shorter key than RSA, which has the characteristics of higher security and faster processing speed. The way of sending data with symmetric encryption and asymmetric encryption is shown in Figure 5.

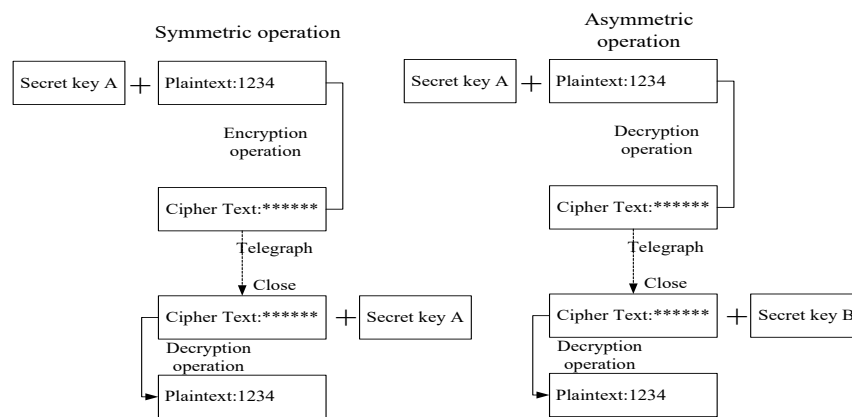

Figure 5. Comparison of Symmetric Encryption and Asymmetric Encryption

2.4 Network Layer

Peer-to-peer (P2P), which belongs to the category of overlay network, is a kind of network information exchange mode relative to C / S mode. P2P network is characterized by decentralization, scalability and high stability. There is no central service node in the network, and each node has the function of providing services and requesting services from other nodes that the server and client have at the same time. In P2P network, the status of nodes in the network is equal, each node can join or exit the network at any time, not limited by the traditional network. In theory, resources and computing power in P2P network can be shared, and nodes can share the pressure of server side in traditional network mode. Therefore, the more nodes in the network, the more resources and services the network can provide, and the smaller the impact of some nodes' failure on the whole network.

2.5 Workflow of Blockchain

Take bitcoin as an example to illustrate the process of block chain generation:

(1) The users of blockchain have a pair of asymmetric keys. The public key can generate the transaction address of users through the algorithm. The private key is mainly used to sign the transaction. After the user initiates the transaction and signs it, the transaction is broadcast to the neighbor node.

(2) The neighbor node receives the transaction and verifies whether the transaction is legal. The legitimate transaction is broadcast in the whole network, and the illegal transaction is discarded directly.

(3) After a period of mining (the process of searching for random numbers to generate blocks in bitcoin is called mining), each node finds out the random numbers that meet the requirements. The nodes will package the verified legitimate transactions into a block with a time stamp in order and broadcast throughout the network.

(4) Other nodes in the network receive the candidate block broadcast and verify that if the block header information and transaction information are legal, the block will be added to the blockchain, and the ledger data will be updated according to the transaction information in the block.

3.Experiments

3.1 Experimental Steps

Agricultural Bank of China, as the leader of blockchain technology in domestic banking industry, its application project of blockchain technology has a great impact, so the next use of event analysis method to analyze the performance of blockchain project in the capital market. In this paper, two time nodes, April 12 and December 18, are selected for research, which are representative. On March 23, 2017, Agricultural Bank of China opened fit for overseas customers in the sub account accounting unit of Shanghai free trade zone through blockchain direct link cross-border payment application technology. On December 18, 2017, Agricultural Bank of China, as an agent clearing bank, completed the RMB position allocation business from Shenzhen Branch of Bank of Hong Kong. The successful launch of the business marks the further application of blockchain technology in Agricultural Bank of China.

In this paper, the market model is used to estimate the normal rate of return, which is easy to operate and more accurate. Therefore, under a series of conditions, the market model is considered as the best choice market model, which assumes that the asset return is subject to the joint normal distribution, and that there is a linear relationship between the rate of return of a stock and the rate of return of the market

$$R_{it} = a_i + \beta_i R_f + \varepsilon_{it}, \quad t \in [T_1 + 1, T_2] \quad (1)$$

Among them, R_{it} and R_f are the daily returns of Agricultural Bank of China stock in different event windows and market indexes on trading day t , a_i is the intercept term, β_i is the household coefficient of Agricultural Bank of China stock, and ε_{it} is the random error term.

$$\hat{R}_{it} = \hat{a}_i + \hat{\beta}_i R_f \quad t \in [T_1 + 1, T_2] \quad (2)$$

\hat{R}_{it} is the normal yield of Agricultural Bank of China under different event windows.

Is abnormal returns.

$$AR_{it} = R_{it} - \hat{R}_{it} = R_{it} - (\hat{a}_i + \hat{\beta}_i R_{it}) \quad t \in [T_1 + 1, T_2] \quad (3)$$

AR_{it} is abnormal returns.

$$CAR_{it} = \sum_{t_1}^{t_2} AAR_{it} \quad T_1 \leq t_1 \leq t_2 \leq T_2 \quad (4)$$

CAR_{it} is the cumulative abnormal return rate under different time windows of Agricultural Bank of China.

3.2 Data Acquisition

This article selects the publication date (or the earliest news release time, excluding the time of false information disclosure) of the application of ABC's blockchain technology as the "announcement date" of the event, that is, $t = 0$; 10 trading days before the announcement date and later 10 trading days, $[-10,10]$, a total of 21 trading days is the event window; the trading day of the year before the event window is the estimation window, SP-years ago.

Since the Agricultural Bank of this article is a company listed on the Shanghai Stock Exchange, it chose Shanghai Stock Exchange as the market index. The source of the data required for this article: Agricultural Bank of China's blockchain technology release date is arranged according to the website of China Merchants Bank. The stock price and the Shanghai Composite Index are from Flush Software. In this paper, python software is used to calculate the income of Agricultural Bank of China on the two event windows of September 12 and December 8 in the past year. The regression results are as follows:

Table 1. Regression Analysis of Parameter Estimation Results of Normal Return Model

Event window day	a (t-value)	b (t-value)	R-squared
September 22	0.0012411*** (1.324)	0.60847*** (8.6241)	0.214
December 18	0.0014752*** (1.2455)	0.52477*** (9.254)	0.247

From the results in Table 1, the normal rate of return in the $[-10,10]$ interval can be calculated, and then the abnormal rate of return and cumulative abnormal rate of return in the event window can be calculated, as shown in the following table:

Table 2.Event (September 22) AR_{1t} and CAR_{1t}

Time	AR_{1t}	CAR_{1t}	Time	AR_{1t}	CAR_{1t}
-10	-0.0010	-0.0010	1	0.0050	0.0188
-9	-0.0036	-0.0048	2	0.0040	0.0245
-8	-0.0021	-0.0024	3	0.0035	0.0265
-7	0.0035	-0.0037	4	0.0047	0.0246
-6	0.0024	-0.0009	5	0.0078	0.0381
-5	-0.0020	-0.0024	6	0.0035	0.0415
-4	0.0012	-0.0015	7	0.0054	0.0482
-3	0.0025	-0.0008	8	0.0065	0.0527
-2	0.0031	-0.0035	9	0.0052	0.0562
-1	0.0058	-0.0099	10	0.0014	0.0613
0	0.00034	-0.0123			

Table 3.Event (September 22) AR_{2t} and CAR_{2t}

Time	AR_{2t}	CAR_{2t}	Time	AR_{2t}	CAR_{2t}
-10	-0.0142	-0.0103	1	0.0056	0.1572
-9	-0.0204	-0.0320	2	0.0354	0.1658
-8	-0.0254	-0.0421	3	0.0368	0.1752
-7	0.0248	-0.0747	4	0.0347	0.2154
-6	0.0402	-0.1157	5	0.0457	0.2614
-5	-0.0301	-0.1452	6	0.0014	0.2654
-4	0.0265	-0.1952	7	0.0084	0.2741
-3	0.0354	-0.2012	8	0.0347	0.3214
-2	0.0215	-0.0952	9	0.0054	0.3271
-1	0.0345	-0.1247	10	0.0621	0.3587
0	0.0471	-0.1324			

To better describe the impact of the introduction of blockchain technology on China Merchants Bank's stock price, this article segments the "event window" interval from 10 trading days before the event, 10 trading days after the event, and the entire event window. Interval analysis, $t = [-10, -1]$, $t = [1, 10]$, and $t = t = [-10, 10]$. this article uses the one-sample T test to test the significance of the abnormal return rate of agricultural banks in each interval. The empirical test results are as follows:

Table 4.Event (22 September) CAR_{1t} Checklis

Event window day	a (t-value)	b (t-value)	R-squared
9月22日	0.0012411*** (1.324)	0.60847*** (8.6241)	0.214
12月18日	0.0014752*** (1.2455)	0.52477*** (9.254)	0.247

Table 5.Event (22 September) CAR_{2t} Checklist

Time window	CAR_{2t}	$t_{CAR_{2t}}$	Accept the null hypothesis
$t=[-10,-1]$	0.1396	5.5487	Refuse
$t=[1,10]$	0.2415	6.0864	Refuse
$t=[-10,10]$	0.3536	5.7544	Refuse

To sum up, the introduction of blockchain technology projects by Agricultural Bank of China can effectively improve China Merchants Bank's stock market performance and bring internal performance and external positive effects to Agricultural Bank of China.

4. Discussion

SWOT-PEST analysis of China Merchants Bank using blockchain technology.

This chapter will use the SWOT-PEST analysis method to analyze the advantages, disadvantages, opportunities, and challenges of using blockchain technology from China Agricultural Bank, and each of these four aspects will be from the four aspects of policy, economy, society, and technology. Specific analysis is made in all aspects, combined with the principles of the blockchain technology analyzed above and the case of China Agricultural Bank using the blockchain technology, and then a comprehensive analysis of the use of blockchain technology by joint-stock commercial banks such as China Merchants Bank. The analysis provides the basis for China Merchants Bank's strategic analysis and policy recommendations for joint-stock commercial banks in the next two chapters. The combination of the two analysis methods will produce an effect of 1 + 1 greater than 2, which can better analyze all aspects of China Merchants Bank's use of blockchain technology, and is more helpful to draw the conclusions of this article. Two types of analysis The method will get 16 combinations through combination, as shown below:

Table 6. Grouping Combination of SWOT and PEST Model

	Policy (P)	Economics (E)	Sociology (S)	Technology (T)
Strength (S)	SP	SE	SS	ST
Worse (W)	WP	WE	WS	WT
Opportunity (O)	OP	OE	OS	OT
Threaten (T)	TP	TE	TS	TT

4.1 Advantage Analysis

(1) Policy Advantages

Since 2016, the blockchain has increasingly received the attention and attention of our government. At present, many policy guidance documents have been issued to promote the development of blockchain in China. The policy environment facing China Merchants Bank is very favorable, and China Merchants Bank launched the landing project of the application of blockchain technology in commercial banks at the time node where China vigorously promoted the development of the blockchain, in line with the direction of policy development. Certain leading role.

China's economic growth has been stable in recent years. In 2017, the GDP reached 82.71 trillion yuan, a year-on-year increase of 6.9%. China's economy has developed steadily and its national strength has gradually improved. Therefore, in the face of the new technology of blockchain, it is easier to look at it with an inclusive and open attitude, and the possibility of development of blockchain technology in China is also possible.

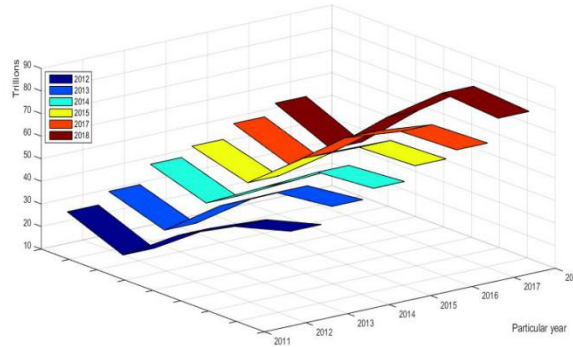

Figure 6. 2012-2017 China's GDP (trillion yuan)

Figure 6 shows the consumption upgrade of domestic residents. Chinese consumers' demand for overseas goods is rising, and the market for outbound tourism and study abroad is growing, so the demand for cross-border payments has increased.

As for the Agricultural Bank itself, according to China Merchants Bank's performance report, as of December 31, 2017, the total assets of the Agricultural Bank were 76.42121 billion yuan, an increase of 56.8% over 2013 and a compound annual growth rate of 11.9%. Exceeds China's GDP growth rate. Agricultural Bank's total assets are very large, and all have achieved rapid growth in total assets, indicating that China Merchants Bank has advantages in economic factors and has the ability to conduct research on blockchain technology. More breakthroughs have been made in application.

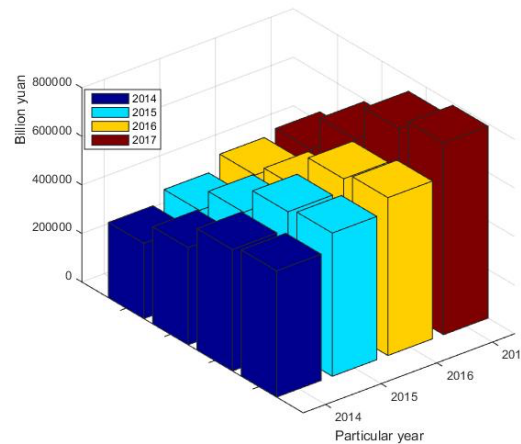

Figure 7.2014-2017 total assets of agricultural Commercial Bank of China (million yuan)

From Figure 7, we can see that the e-commerce platform is becoming more mature. Many residents in China like Haitao and pay for orders online, thus increasing demand for cross-border payments

(2) Social Advantage

According to statistics, since 2012, the number of global startup and innovation companies engaged in the blockchain field has grown rapidly at a rate of more than 65.2%, and many domestic companies have also caught up to the wave of this technological revolution. According to the latest "China Blockchain Industry Development White Paper" released in 2017, China added 17 new blockchain companies in 2016 alone, which allowed China to surpass the United States for the first time, ranking the world in the number of blockchain companies the first. As of March 2018, China has published nearly 1,200 blockchain patents, and Alibaba tops the list.

This shows that Chinese companies attach great importance to blockchain technology. Under this background, the combination of blockchain and commercial banks is one of the directions for the development of blockchain in the future, and there will be many development opportunities. At the same time, Bank of China is the only non-tech company in the top ten of China's list of blockchain technology patents. Commercial banks attach great importance to blockchain technology. China Merchants Bank entered the blockchain field for research and development in 2015 with the rapid development of blockchain technology and launched application projects in 2017, which were more or less affected by social factors.

(3) Technical Advantages

Agricultural Bank has strategically built its scientific and technological basic capabilities. At the beginning of March 2017, Agricultural Bank and 11 other sister organizations joined a group of 122 global members to conduct research on the application of blockchain technology. In the second half of 2017, Agricultural Bank of China proposed that fintech was the nuclear power in China Merchants Bank's strategic transformation. The Agricultural Bank of China will focus on the construction of payment, data, and scientific and technological capabilities to promote the development of financial technology in the agricultural bank. Agricultural Bank of China ranked 21st in the list of China's R & D investment companies in 2017 and is the only bank among the top 100 companies on the list. Therefore, China Merchants Bank has certain advantages in terms of technical factors.

4.2 Disadvantage Analysis

(1) Policy Disadvantages

The construction of China's blockchain system is still not perfect. It lacks corresponding supporting measures and specific operational implementation rules. The effectiveness of policy implementation still needs to be strengthened. Commercial banks lack unified industry technology when studying the application of blockchain technology Standards, this aspect requires the banks to explore on their own. The development of blockchain technology in Agricultural Bank of China under such a policy environment may take some detours. In addition, the supervisory authority's supervision of commercial banks is becoming stricter. Before the commercial bank's living environment was not as good as before, Agricultural Bank also needs to make timely adjustments under the new policy to comply

with the direction of supervision. In the middle, it may lose sight of each other and ignore it. Research on the application of blockchain technology.

(2) Economic Disadvantage

This article selects two well-developed urban commercial banks in Zhejiang Province for comparison and compares them from two aspects: total asset growth rate and net profit. Since the performance of some commercial banks in 2017 has not been announced, this article selects the rapid development of fintech from 2013 to 2016 for comparison, as follows:

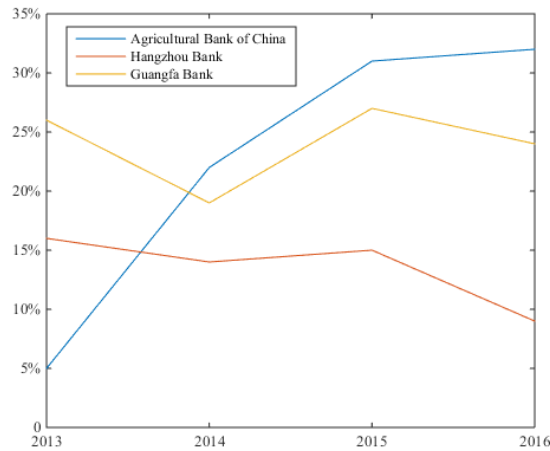

Figure 8. Comparison of the Year-on-year Growth Rate of Total Assets of Different Commercial Banks in 2013-2016

It can be clearly seen from the growth rate of the total assets of the three banks that the growth rate of the total assets of the Agricultural Bank of China has shown a downward trend. Compared with 2014, the growth rate of the total assets of the agricultural bank has fallen by half. In contrast, the total asset growth rate of Bank of Hangzhou and Bank of Ningbo has been at a relatively high level, and overall, it is much higher than that of Agricultural Bank. It can be seen from this table that Agricultural Bank is much slower than Hangzhou Bank and Guangfa Bank in terms of scale expansion, so the economic development situation is worse than the latter two.

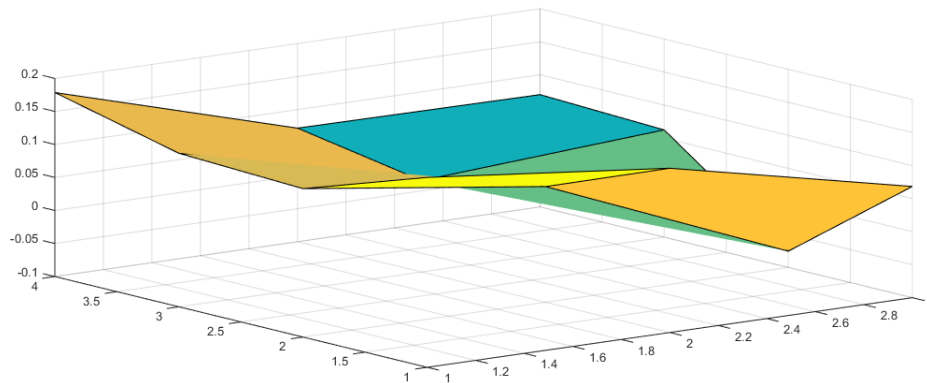

Figure 9. Comparison of the Year-on-year Growth Rate of Net Profit of Different Commercial Banks in 2013-2016

According to the net profit growth rate of the three banks in this figure, the growth rate of agricultural bank's net profit was high in 2013 and 2014, and it dropped sharply by 2015, which shows that the operating environment has changed. On the contrary, Hangzhou Bank and Guangfa Ningbo Bank's net profit growth rate is relatively stable, which shows that under the pressure of economic downturn, Hangzhou Bank and Guangfa Bank are better than Agricultural Bank. Hangzhou Bank's low net profit growth rate may be related to the development strategy, and the growth rate of the bank's net profit has been maintained at a high level. Combining Figures 8 and 9, Agricultural Bank is not as good as Hangzhou Bank and Guangfa Bank in terms of overall growth.

(3) Social Disadvantage

The proportion of commercial bank loans in the social financing structure is getting lower and lower. The proportion of direct financing has increased from 4.9% in 2002 to 32.06% in 2015. The phenomenon of financial disintermediation has become increasingly serious. With the development of commercial banks, the trend of disintermediation is becoming more and more obvious. Internet-based big data analysis of Internet finance can alleviate information asymmetry to a certain extent. Compared with commercial banks, Internet finance has certain advantages. Payment and settlement and risk management provide more efficient and lower-cost methods. In this way, competition in the financial market is becoming more intense, and the monopoly profits of commercial banks are being eroded, including the profits of agricultural banks.

(4) Technical Disadvantages

On the one hand, joint-stock commercial banks are technically incomparable with Internet companies such as Tencent, Baidu, and Alibaba. Alibaba has ranked first in the world in the number of blockchain technology patents, and Alibaba's Alipay and Yu'e Bao, etc. Has had a great impact on China's commercial banks. Chinese enterprises attach great importance to blockchain technology. Under this background, the combination of blockchain and commercial banks is one of the directions for the development of blockchain in the future, and there will be many development opportunities. At the same time, Bank of China is the only non-tech company in the top ten of China's list of blockchain technology patents. Commercial banks attach great importance to blockchain technology. China Merchants Bank entered the blockchain field in 2015 for the rapid development of blockchain technology for research and development and launched application projects in 2017, which were affected by social factors.

5. Conclusions

Based on the theoretical analysis of blockchain technology and the introduction of the application of ABC's cross-border payment and settlement system, this paper tests the performance of ABC's blockchain technology application through the event method and obtains the blockchain. The application of technology can improve and improve the stock market performance of commercial banks; further use the SWOT-PEST analysis method, combined with the advantages and disadvantages and opportunities and challenges of China Merchants Bank's blockchain application, analyze the possible existence and facing of China Merchants Bank's blockchain application. The problem.

This article first introduces the characteristics and principles of blockchain technology in a comprehensive way. The principal part mainly discusses blockchain from the perspective of economics and financial intermediation theory and analyzes the disintermediation and Internet under financial disintermediation. The re-intermediation of finance and the blockchain can reshape financial intermediation. The impact of financial disintermediation and Internet finance on traditional financial intermediaries is particularly large. Secondly, it analyzes the case of agricultural

bank using blockchain technology and analyzes the application of agricultural bank. The background of blockchain technology can be seen in the general context of the need for new technology to break through existing limitations, and the emergence of blockchain technology is a good choice for commercial banks. The background analysis of the international payment and clearing system can see that the development potential of the cross-border payment and clearing field is great. Through specific analysis of the agricultural bank's practice of using blockchain technology, it can be seen that the blockchain technology has brought many Benefits, through the innovative combination of traditional cross-border business and ABC's blockchain, analyzes the capabilities of ABC's blockchain Collection business, to improve cross-border remittances made and letters of credit, which are using good information block chain technology for the Agricultural Bank, China Merchants Bank, and finally the application of the effect block chain technology to analyze part of the case, select Analyze the events at two representative time nodes, and conclude that the launch of the blockchain technology project by Agricultural Bank of China can effectively improve the performance of Agricultural Bank;

Finally, the combined SWOT analysis and PEST analysis of China Merchants Bank up using block chain technology to conduct a comprehensive analysis, with a certain degree of innovation, SWOT analysis separately from the strengths, weaknesses, opportunities and challenges in four areas for analysis, each and a specific aspect of the policy, economic, social, technological these four aspects, through a comprehensive analysis can come to a better use of joint-stock commercial bank block chain technology for analysis and decision, in order to make a better judgment. This is an analysis of the use of agricultural bank block chain technology favorable: many policies to promote the development of the policy block chain, block chain opportunities for cooperation with local governments to increase; the Agricultural Bank of large overall size of the economy and reshape the financial block chain technology intermediary's great development potential; the community of block chain industry developed rapidly, the number of patents. Currently there are defects in credit terms, block chain technology has its uses? Technically Merchants Bank put a lot of commercial banks and the block chain can achieve a breakthrough in many development bottlenecks; downside: the lack of policy Block chain technology industry standard, commercial banks face tighter regulatory environment; the economy Agricultural development Bank as fast as some banks; financial disintermediation a serious social phenomenon and promotion of new technologies more slowly? , Technical problems not as large technology companies, large Internet companies and large commercial banks, and the presence of the block chain technology performance and security of the Agricultural Bank, China Merchants Bank and then analyzed using block chain technology problems faced, such as technical performance issues, security issues, regulatory issues and business model problems. Through comprehensive analysis of the Agricultural Bank of China, Agricultural Bank of final use of the block chain technology offers some policy recommendations.

References

- [1]Fabio Bertoni, & Stefano Lugo. (2018) "Detecting abnormal changes in credit default swap spreads using matching-portfolio models",*Journal of Banking & Finance*, 54(09)pp.90.
- [2]Annette Mackenzie. (2015)"The fintech revolution",*London Business School Review*, 26(3), pp.50-53.
- [3]Gina C Pieters, & Christoffer Koch. (2017) "Blockchain Technology Disrupting Traditional Records Systems", *Social Science Electronic Publishing*, 6(2),pp. 1-3.
- [4]Weizhi Meng, Elmar Tischhauser, Qingju Wang, Yu Wang, & Jinguang Han. (2018) "When Intrusion Detection Meets Blockchain Technology", a review. *IEEE Access*, 6(1), pp.10179-10188.
- [5]Christian Esposito, Alfredo De Santis, Genny Tortora, Henry Chang, & Kim-Kwang Raymond Choo. (2018) "Blockchain: A Panacea for Healthcare Cloud-based Data Security and Privacy", *IEEE Cloud Computing*, 5(1), pp.31-37.

- [6]Matthew B. Hoy. (2017) “An Introduction to The Blockchain And Its Implications for Libraries And Medicine”,*Medical Reference Services Quarterly*, 36(3), pp.273-279.
- [7]Valentina Gatteschi, Fabrizio Lamberti, Claudio Demartini, Chiara Pranteda, & Victor Santamaria. (2018) “To Blockchain or Not to Blockchain:That is The Question”, *It Professional*20(2), pp.62-74.
- [8]Kim, Henry, & Laskowski, Marek. (2018) “A perspective on Blockchain Smart Contracts: Reducing Uncertainty And Complexity in Value Exchange”,*Ssrn Electronic Journal*, pp.1-6.
- [9]Jong-Hyoun Lee. (2017) “Bidaas: Blockchain Based Id as A Service”,*IEEE Access*, (99), pp.1-1.
- [10]Christian Sillaber, & Bernhard Waltl. (2017) “Life Cycle of Smart Contracts in Blockchain Ecosystems”, *Datenschutz und Datensicherheit - DuD*,41(8), pp.497-500.
- [11]Singh, Madhusudan, & Kim, Shiho. (2017) “Intelligent Vehicle-trust Point: Reward Based Intelligent Vehicle Communication Using Blockchain”,*Optical Engineering*, 33(1), pp.701-709.
- [12]Bert Scholtens, Pontus Cerin, & Lars Hassel. (2008) “Sustainable development and socially responsible finance and investing”,*Sustainable Development*, 16(3), pp.137-140.
- [13]Florian Hawlitschek, Benedikt Notheisen, & Timm Teubner. (2018) “The limits of trust-free systems: a literature review on blockchain technology and trust in the sharing economy”,*Electronic Commerce Research & Applications*, pp.29.
- [14]SINCLAIR DAVIDSON, PRIMAVERA DE FILIPPI, & JASON POTTS. (2018) “Blockchains and the economic institutions of capitalism”,*Journal of Institutional Economics*, 14(4), pp.1-20.
- [15]M. Andrychowicz, S. Dziembowski, D. Malinowski, & Ł. Mazurek. (2016) “Secure multiparty computations on bitcoin”,*Communications of the Acm*,59(4),pp.76-84.
- [16]David Yermack. (2017) “Corporate governance and blockchains”,*Social Science Electronic Publishing*, 21(1), pp.7-31.
- [17]Polasik, M., Piotrowska, A., Wisniewski, T. P., Kotkowski, R., & Lightfoot, G. (2015) “Price fluctuations and the use of bitcoin”,an empirical inquiry. ,20(1), pp.9-49.
- [18]LI Hui-jia, & LONG Min. (2015) “Construction of one-way hash function based on spatiotemporal chaotic system with double-perturbation”,*Journal of Chinese Computer Systems*, 41(2), pp.191-199.
- [19]Yongzhi Wang, Yulong Shen, Hua Wang, Jinli Cao, & Xiaohong Jiang. (2016) “Mtmr: ensuring mapreduce computation integrity with merkle tree-based verifications”,*IEEE Transactions on Big Data*, PP(99), pp.1-1