



## **Recent Advances in Sensing Technologies for Smart Cities**

**K. Shankar**

Department of Computer Applications

Alagappa University

Karaikudi, India

Email: [drkshankar@ieee.org](mailto:drkshankar@ieee.org)

### **Abstract**

Generally, in smart cities, a group of sensing devices, cameras, data centers will exist that enables the civilian administrators to offer needed services in a rapid and efficient way. The effective usage of advanced technologies assists to the creation of intelligent transportation, smart healthcare, smart buildings, and so on. In case of smart building, holds the nature of gathering rain water for future system, smart control, the probable enhancements allowed by the sensing technologies is high. The ubiquitous sensing offers various limitations which are technical or social in nature. In this chapter, an explanation of the different concepts involved to the topic of sensing in smart cities is provided. This chapter comprises a brief history, sensing platform, sensing technologies, challenges and its applications in a broader view. At the end of this chapter, it will enable the readers to clearly understand the concept of advanced sensing technologies in smart cities.

**Keywords:** Smart city; IoT; Cloud; Sensing technologies;

### **1.Introduction**

Smart cities generally functions in a sustainable and intellectual way by the incorporation of every infrastructure and services to an interconnected whole. It also enables seamless observing and managing the smart city by the utilization of smart devices to verify ensuring sustainability and effectiveness [1]. Due to the rise in the global population, resource utilization becomes adequately high resulting to the shortage of resources and climatic changes; the motivation for inventive solutions becomes important. Especially, in urban regions, maximum amount of resource utilized is noticed and it raises an immediate requirement of creating smart infrastructure. To resolve the issues, a series of enhancements are considered as the major elements of urban dynamic, as shown in Fig.1.

It is identified that the world's financial system will be considerably inconsistent because of the development in the city side. In the next 30 years, it is predicted that a total of 6 billion people lives in urban regions. This development will exaggerate additional presented power and weather related difficulties. For resolving the issues, cities should utilize the resources effectively and advanced technologies need to be derived.

Under the category of smart infrastructure, sensing plays a vital role that has the ability to observe and take actions by their own cleverly. By the use of sensing devices to supervise public infrastructures like roads, bridges and buildings, offer responsiveness which enables high resource utilization depending upon the data gathered by the sensors. Different types of sensors can be utilized in the application of smart cities namely proximity sensor, gas sensor, pressure sensor, level sensor, electro-optical sensor, smoke detector, passive infrared sensor, image sensor, motion sensor and so on. The real-time observance reduces the requirement of periodic supervision, hence, it minimizes the cost, determines utilization of energy in houses enables precise load prediction, and sensors installed

in roads to monitor traffic gather data that is needed to implement the intelligent transportation systems (ITS). In many cities, pilot projects are implement to ensure advanced technologies which assists to resolve the urban sustainability challenges, enhance the efficiency of urban services, and improve the quality of life. These projects are mainly labeled as “smart city” projects, are classically supported by municipality, funded by subsidy, and run in partnerships.

To achieve the efficiency, massive number of sensors should undergo deployment and needs t be linked together for the purpose of gathering and communicating data to the central receiver where decision making in an intelligent way takes place. If offers numerous challenges. Initially, a communication infrastructure in needed to make the communication of sensors possible. Next, an effective way of data processing and aggregation is also required [2].

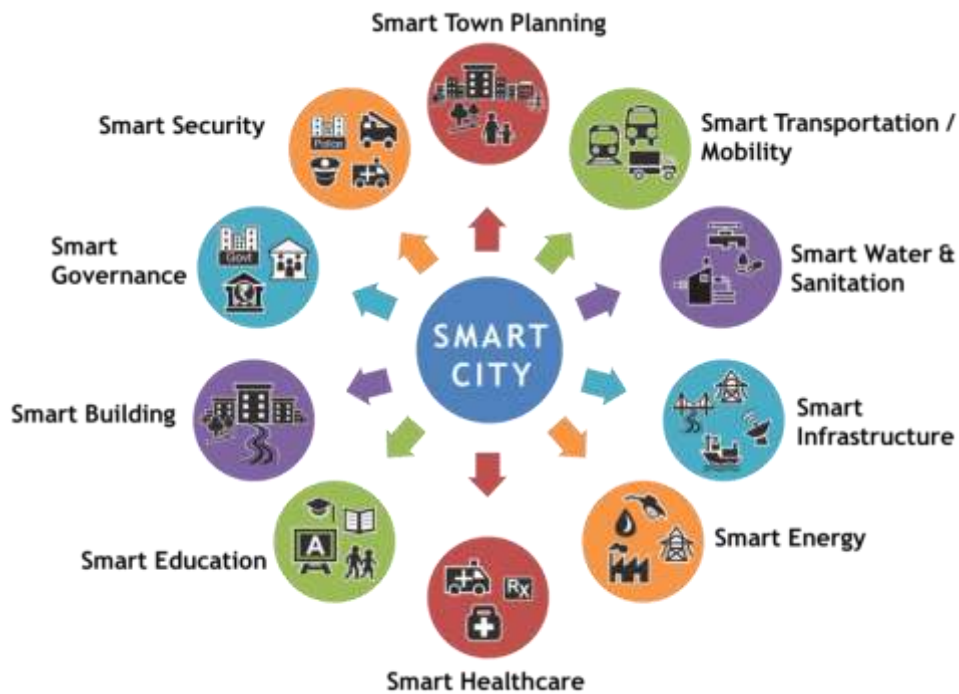

Figure 1: Sensing applications for smart cities

The different views relevant to the sensing technologies in smart cities and effective data processing gathered by the sensors are explained in the remaining sections.

## 2. Rise of sensing technologies

Sensors play an important element of any in intelligent control system [23]. The ease of use of a huge number of diverse sensors and constantly developing technologies allows the applications which are not feasible in the earlier days because of expensive and restricted availability. The advanced technologies not only stimulate the inventions, it also allows needed computation power for small-scale devices that can be interfaced to the sensors in an inexpensive way. In the view of the need of smart cities, extensive accessibility of these technologies converts to a massive chances with respect to sensing.

Under the concept of smart city, the conventional way of using meters to measure water, fuel, electricity usage can be replaced. The usage of smart metering indicates the recent invention of technologies [3]. Along with the mechanical solution, it should be healthy, inexpensive, simple to manage and reliable, since the reading values are applied to bill the utilization. Electricity meter reading values are developed for minimizing cost and improve the

precision of meter readings, eventually to an advanced metering infrastructure (AMI) that differs from the AMR in that it allows two-way communication with the meter, driven by a rising thoughtful of the benefits of two-way interactions among system operator, consumer and their load and resource[26]. A sensor is a transformer that converts the physical variables to electronic signals that could be interpreted by human or provided to an autonomous model [26]. The signals in traditional sensors such as temperature, light, humidity, pressure, moisture and diverse variables. Added classy sensing devices like accelerometers could be utilized to determine acceleration and vibration. Under structural health monitoring (SHM), for example, corrosion rate sensors (based on the idea of maximizing in electrical resistivity because of corrosion); acoustic emission sensor (employed for detecting sound wave propagation); and magneto-strictive sensors (identify the modification in magnetic induction in the material due to strain or stress).

Recent invention of sensing devices are mainly depends upon various aspects of semiconductor devices, nano technologies and smart sensing devices like smart phones [4]. CMOS based sensing, because of relatively cheap, allows diverse smart sensors. In [5], a smart temperature sensor with a one-point calibration method and MOSFET circuit is presented. This sensor is mainly focused on low powered devices. Some other CMOS-based sensor applications have the capability to monitor the food product quality by reading the temperature, exposure time, to assess the food product quality [6]. Under the concept of smart city, these devices are used to observe air and water quality. Particularly, printed sensors could be linked to the devices as labels for measuring diverse physical variables like humidity, vibrations, and so on. In addition, sensor has been designed in synthetic foil, for example, chemical gas sensors are designed on different types of substrates, coated with a sensing film [7]. It allows the sensing of many variables from an individual sensor.

A probable application for the sensing devices is the observance of humidity by embedding these sensors to building materials, or ecological monitoring [8], a significant ability for smart cities. Nano-technology, though typically appropriate for bio-sensing applications, is one of the enabling technologies for sensor development, as advancements in nano-technology will unquestionably make growth in MEMS and photonics, unavoidably resulted to the design of extremely complicated, however, inexpensive sensors. These technologies allow the applications to sense the environment of the person as well as person's health at minute level is also connected to the social media.

Rapid growth in the production of smart phones creates a completely novel scenario. Smart phones are interconnected to diverse types of sensors like accelerometer, gyroscopes, and compass, allowing diverse crowd sourcing applications that will ultimately be augmented by the Internet of Things (IoT).

### **3. Enabling Technologies**

Few technical challenges related to communication among the sensor nodes are yet to be solved [24]. Under the concept of Internet of Things (IoT), the data transmission among the sensors nodes needs to be operate in a wirelessly way, since cabling cost for numerous sensors is not practical and also costly. The low power communication standards applicable for massive devices and their heterogeneous nature are essential [9]. Particularly, based on the position and essential coverage, dissimilar networks are existing in smart cities. Based on the place as well as coverage, these can be categorized in [10]:

Home Area Networks (HAN): It classically makes use of small range standards with the frequency operating in the ISM band. The standards comprises ZigBee, Dash7 and Wi-Fi (802.11 g/n), or wired standards like Ethernet. Every monitor and control system elements in a house are linked to a HAN.

Wide Area Networks (WAN): It offers data transmission among the utilities and customers' premises that needs broad coverage compared to HAN, with the infrastructure like leased lines depending upon optic fiber cable or wireless, and controlled by the service provider.

Field Area Networks: Generally employed in a smart grid to link the building of a customer to substation.

## 4. Sensing Platforms

By means of the initiation of ubiquitous sensing, diverse devices and platforms presently exist. Though thoughts to realize these platforms have been present in several years; it becomes possible due to the inexpensive electronic components. The way of sourcing these components in massive volume becomes very cheap due to the progression in technologies. The sensor nodes can be linked to numerous sensors which could be temperature, gas, and pressure sensors [11]. The platforms are constructed in an idea that the observed data is gathered by the sensors, occasionally pre-processed, and again sent to the base station through added sensor nodes, therefore, they are generally placed in a network called as wireless sensor network (WSN) [31]. In addition, these systems undergo outdoor deployment and have to manage in harsh ecological condition.

### 4.1. WSN

WSN has numerous sensor nodes that are linked to a processing unit, communication unit, analog to digital converter, sensor array, storage area and battery. The traditional structural design of a sensor node in WSN is shown in Fig. 2.

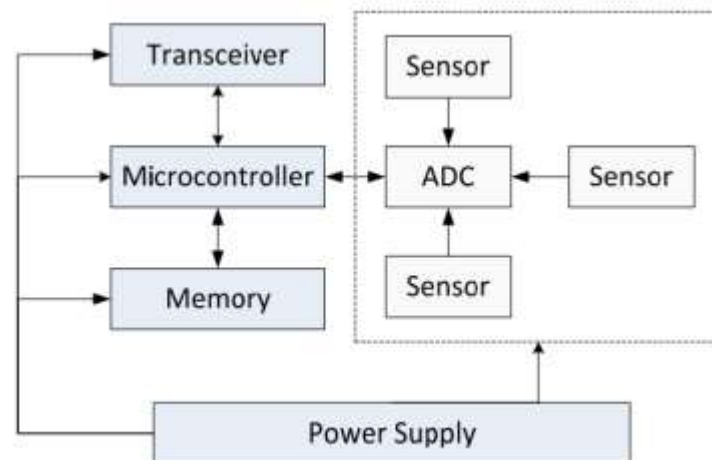

Figure 2: Structural design of a sensor node

The utopia of WSNs is a tremendously minute low powered, inexpensive sensor nodes which has undergone deployment in any area with adequate battery supply that could last for some years with the ability to seamlessly observe its environment [30]. In real time, even with the latest advancements in microelectronics, these are not yet implemented.

### 4.2. IoT System

The sensing devices generally transmit the data to based station which again transmits it to any kind of processing centre. These two elements are implicitly unified, from a WSN point of view. Few of the integrated solutions comprise:

Thingspeak: An environment that allows the user to enter details to the cloud from the sensor nodes. The user creates an account, performs device registration and gain access to the gathered data as preferable. This system enables to query by location, enabling the user for having data accessing from diverse parts of the globe.

iOBridge: Unlike Thingspeak and Cosm, iOBridge design its individual hardware module which is linked to the cloud and it could be accessed by the use of web interfaces to monitor from remote areas and the API's enables the incorporation of gathered data to furtherweb services or third-party applications, for instance, mobile applications are developed to control the ioBridge devices.

#### 4.3. Cloud of Things

Cloud is an important element of a smart city. Since the sensor nodes gather terabytes of data, it is required to be integrated and computed. Along with the latest technical advancements in the form of smart phones, cloud becomes an important component for storing as well as processing data. Simply, the cloud represents a set of platforms and infrastructure to where data is saved and processed, enables the retrieval and uploading of user data for a particular application or software programs, anywhere [12] with the existing Internet usage. So, the cloud allocates massive resources easily reached by Internet. The capability of outsourcing processing power is mainly attractive, due to the fact that the resource intensive applications can be transmitted to the Cloud as an alternative. In the view of ubiquitous computing and sensing, cloud becomes mandatory.

### 5. Applications

This section discusses the possible applications of smart cities are presented here.

#### 5.1. Electricity Distribution System

With contrast to the conventional power grid, smart grids brought various enhancements. Initially, it offers self-monitoring abilities, where sensors undergo deployment [13] at any place on the distribution network, in positions like substations or overhead transmission lines. The sensed data can be further employed for reporting related events. A main sensing application in smart grid among the other ones is the observation of overhead in transmission line. Through the line monitoring, the utilities verify that the delivery of power takes place with the safe limits. For example, STAMP [14] senses the sag, tension value and temperature of an overhead line in real-time to compute the status or line health from the measurement (as shown in Fig. 3).

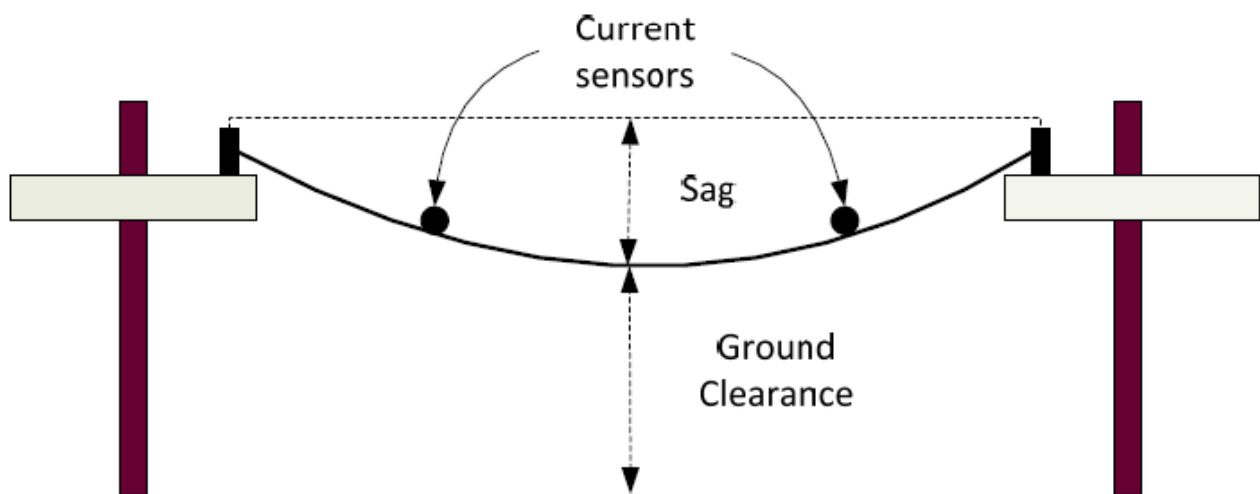

Figure 3: Sensors placement in transmission line

5.2. Environmental Monitoring

For ensuring the quality of living, safety, environment monitoring gains more significance. Through the observation of qualities of various variables like air, gas, water and so on, it is probable to evaluate anomaly in the surrounding; so, verifying pollution is kept back to a satisfactory level. Particularly, minimizing the carbon emission level that is a severe threat to the planet is a primary goal of smart city. The environmental monitoring needs a deployment of diverse sensor outdoor environment like park, river and so on.

5.3. Water Distribution Systems

The advancements in sensing technology allow developing a highly reliable fault identification model. The probable positions of deploying sensors and interested parameters from an observation viewpoint, in water distribution system is illustrated in Fig. 4.

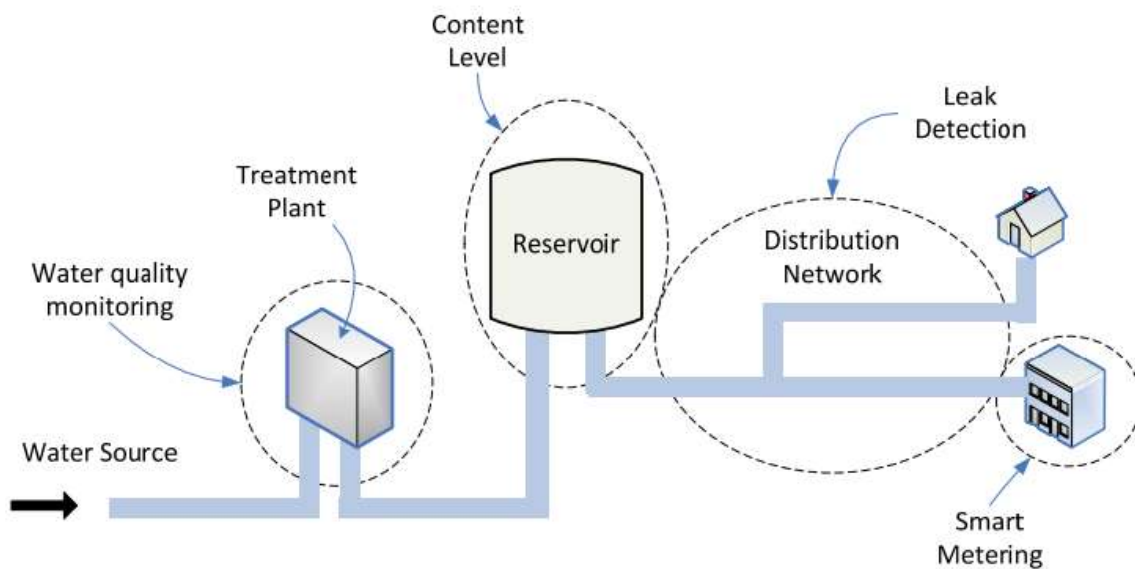

Figure 4: Water distribution system

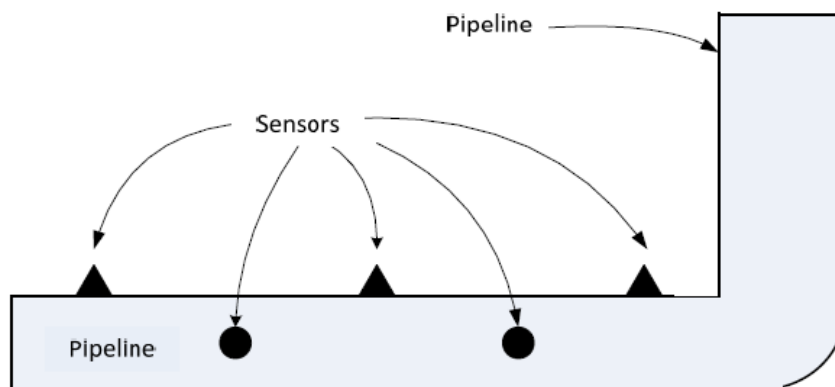

Figure 5: Pipeline monitoring

Some instances of those applications include observing the level of water in reservoir, identification of leaks and observing the quality of water at particular points the distribution system. To monitor the pipelines, [15] comprised a collection of sensors which has undergone deployment around the pipeline to monitor unnecessarily. In general, a set of three variables are applied to identify the presence of faults in the pipeline like sound, pressure, and vibration as given in Fig. 5.

#### 5.4. Intelligent Transportation Systems

Due to the exponential increase in the number of cars all over the globe, there is a great demand to manage the traffic efficiently for avoiding traffic jam, optimal route selection, and so on. The traditional way of regulating traffic flow is the usage of traffic lights. It is generally placed at predefined switch an interval time that is not dynamic to the flow of traffic [28]. The traffic jam greatly affects the usage of fuel because of adequate start and stop and increases the emission carbon content. Therefore, a dynamic method based on the flow of traffic is highly essential. In this way, a model to determine the total number of cars coming towards a point to produce data for switch interval times to be vigorously altered depending upon the flow of traffic [16]. In this case, smart applications needs to be designed, effective models to identify the traffic are needed.

#### 5.5. Smart Building and Home

By taking an attempt of promoting green living and sustainability, diverse actions take place to reduce energy usage in buildings. In this way, approaches to mainly minimize the utilization of energy in buildings are diverse from smart models to smart design [17]. It is essential due to the fact that buildings (particularly with the easier convenience to low-cost electrical appliances and so on) take a very big piece of produced electricity.



Figure 6: Facilities offered in smart buildings

Particularly, heat, ventilation and air conditioning (HVAC) comprises the largest contributor to enhanced utilization. Therefore, sensing is important is critical in buildings for proper events for reducing utilization is carried out. For realizing automation systems, for example, prior to suitable event is carried out, the state of the atmosphere has to be correctly assessed. Since the heart of household energy sensing are smart meters. Energy sensing measurements undergo interfacing with a smart meter for precise utilization report. Some of the facilities provided in smart buildings are shown in Fig. 6.

### **5.6. Surveillance**

Using the existence of CCTV cameras for surveillance purpose, an infrastructure for smart surveillance system is present [27]. An important aspect needs to be considered in a smart city is security [22]. Though the cameras are generally lined to a digital video recorder (DVR), it does not have any inbuilt processing abilities. In addition, they are controlled by manual operators who might have lack of attentiveness. The advantages of having smart surveillance are noticeable [18]. For example, by the observation of the events initiated by the people, it is probable to identify the occurrence of violence or people trying to involve in it.

In this view, the smart surveillance system can raise an alarm by the occurrence of event which is predefined. In addition, the observance of people's nature can also help to determine the pedestrian traffic pattern that could be helpful to develop any further assistance for pedestrians.

### **5.7. Health Care**

An essential application of sensing devices lies in the field of healthcare. For facilitating management in medical institutions, sensing devices can be utilized in the environment for diverse applications [29]. Particularly, wireless body area networks (WBANs) is a hot research area which contains a set of interlinked sensors placed in various body parts to measure the physical variables that can be electrocardiography (ECG), breathiness, temperature, blood pressure and so on [19]. The benefit of WBANs is their ability of uploading data to remote systems. Hence, the gathered data can be seen by the doctors in real world. Emergency response is also another view of sensing applications in healthcare [20].

## **6. Design issues**

Some of the design issues exist in the area relevant to the smart societies are listed below and also demonstrated in Fig. 7.

**Security:** The usage of various technologies for sensing applications faces numerous challenges that might be treated in the area of smart cities. These networks are easily vulnerable to cyber-terrorism and cyber-vandalism.

**Data rights and privacy:** An issue arises in the view that who will have the right for every data gathered by the sensing applications. For example, water distribution management has the ability to access a home's water consumption; there is a question whether that data be utilized with no control from anyone.

**Trust:** it is a significant factor that how to trust the objects to aggregate and store the data. For example, the cloud can be treated as a centralized system where data access is generally managed by the organization that has its own infrastructure.

**Social Issues:** Civilian people have been keenly observed in a city. For example, there are mutual initiatives where citizens gather and make the city clear. It has to be considered that whether the smart city concept generates some kind of disconnectivity among the citizens and the city.

Non-distributed control: it is obvious from the current scenario is shifted towards the non-distributed way where every service is continuously aggregated, to be controlled by an individual centralized system. It will transfer the entire management by the leading bodies that could be utilized for tracking people in an illegal way. It is relevant to the issues of privacy and trust which is explained in earlier.

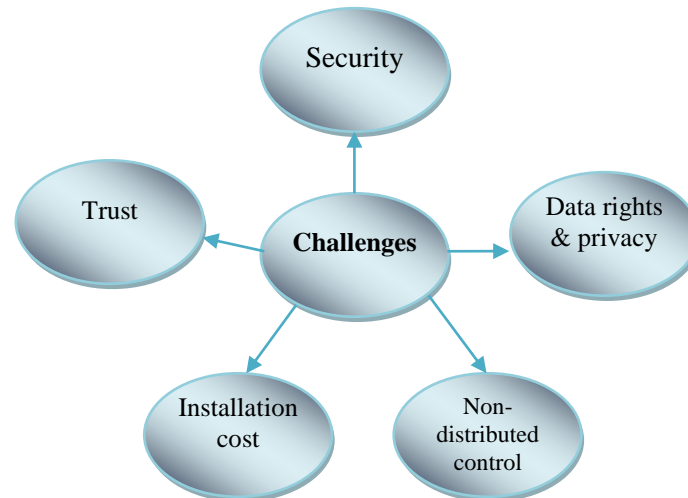

Figure 7: Challenges related to smart city

Installation cost to upgrade smart cities: It is a major design issue which should consider the cost needed to upgrade the cities. Since smart cities are mainly based on communication and other infrastructures, it requires high cost to update every existing model.

## 7. Conclusion

In urban regions, a maximum amount of resource utilized is noticed and it raises an immediate requirement of creating smart infrastructure. To resolve the issues, a series of enhancements are considered as the major elements of urban dynamics and the concept of smart city has been mainly developed. The different views relevant to the sensing technologies in smart cities and effective data processing gathered by the sensors are explained in this chapter. In addition, different applications and challenges exist in the view of smart cities are also neatly discussed in this chapter.

## REFERENCES

- [1] Zheng, L., Kwok, W.M., Aquaro, V. and Qi, X., 2019, April. Digital Government, Smart Cities and Sustainable Development. In Proceedings of the 12th International Conference on Theory and Practice of Electronic Governance (pp. 291-301). ACM.
- [2] Matos, A., Pinto, B., Barros, F., Martins, S., Martins, J. and Au-Yong-Oliveira, M., 2019, April. Smart Cities and Smart Tourism: What Future Do They Bring?. In World Conference on Information Systems and Technologies (pp. 358-370). Springer, Cham.
- [3] Ismagilova, E., Hughes, L., Dwivedi, Y.K. and Raman, K.R., 2019. Smart cities: Advances in research— An information systems perspective. *International Journal of Information Management*, 47, pp.88-100.
- [4] Cardullo, P. and Kitchin, R., 2019. Smart urbanism and smart citizenship: The neoliberal logic of ‘citizen-focused’ smart cities in Europe. *Environment and Planning C: Politics and Space*, 37(5), pp.813-830.
- [5] Ueno, K.; Asai, T.; Amemiya, Y. Low-power temperature-to-frequency converter consisting of sub-threshold CMOS circuits for integrated smart temperature sensors. *Sens. Actuators A* 2011, 165, 132–137.

- [6] Ueno, K.; Hirose, T.; Asai, T.; Amemiya, Y. CMOS Smart Sensor for Monitoring the Quality of Perishables. *IEEE J. Solid State Circuits* 2007, 2, 798–803.
- [7] Liu, Y., Yang, C., Jiang, L., Xie, S. and Zhang, Y., 2019. Intelligent edge computing for IoT-based energy management in smart cities. *IEEE Network*, 33(2), pp.111-117.
- [8] Oprea, A.; Courbat, J.; Bârsan, N.; Briand, D.; Weimar, U.; de Rooij, N. Multi sensor platform on plastic foil for environmental monitoring. *Procedia Chem.* 2009, 1, 597–600.
- [9] Park, C.; Lee, J. Intelligent Traffic Control Based on IEEE 802.11 DCF/PCF Mechanisms at Intersections. In *Proceedings of IEEE Conference on Vehicular Technology(VTC 2010)*, San Francisco, CA, USA, 5–8 September 2011; pp. 1–4.
- [10] Hamaguchi, K.; Ma, Y.; Takada, M.; Nishijima, T.; Shimura, T. Telecommunications Systems in Smart Cities. *Hitachi Rev.* 2012, 61, 152–158.
- [11] Myung, H.; Lee, S.; Lee, B. Structural health monitoring robot using paired structured light. In *Proceedings of IEEE International Symposium on Industrial Electronics (ISIE)*, Seoul, Korea, 5–8 July 2009; pp. 396–401.
- [12] Yun, J.; Won, K.-H. Building Environment Analysis Based on Temperature and Humidity for Smart Energy Systems. *Sensors* 2012, 12, 13458–13470
- [13] Lloret, J.; Macías, E.; Suárez, A.; Lacuesta, R. Ubiquitous Monitoring of Electrical Household Appliances. *Sensors* 2012, 12, 15159–15191.
- [14] Klein, K.; Springer, P.; Black, W. Real-Time Ampacity and Ground Clearance Software for Integration into Smart Grid Technology. *IEEE Trans. Power Deliv.* 2010, 25, 1768–1777
- [15] Metje, N.; Chapman, D.; Cheneler, D.; Ward, M.; Thomas, A. Smart Pipes—Instrumented Water Pipes, Can this be made a reality? *Sensors* 2011, 11, 7455–7475.
- [16] Metje, N.; Chapman, D.; Cheneler, D.; Ward, M.; Thomas, A. Smart Pipes—Instrumented Water Pipes, Can this be made a reality? *Sensors* 2011, 11, 7455–7475. 45. Min, L.; Yan, W.; Wassell, I. Wireless sensor network: Water distribution monitoring system. In *Proceedings of IEEE Radio and Wireless Symposium*, Orlando, FL, USA, 22–24 January 2008; pp. 775–778.
- [17] Klein, K.; Springer, P.; Black, W. Real-Time Ampacity and Ground Clearance Software for Integration into Smart Grid Technology. *IEEE Trans. Power Deliv.* 2010, 25, 1768–1777
- [18] Metje, N.; Chapman, D.; Walton, R.; Sadeghioon, A.; Ward, M. Real time condition of buried water pipes. *Tunneling Undergr. Space Technol.* 2012, 28, 315–320. 48. Gungor, V.; Lu, B.; Hancke, G.P. Opportunities and Challenges of Wireless Sensor Networks in Smart Grid. *IEEE Trans. Ind. Electr.* 2010, 57, 3557–3564.
- [19] Brown, L.; Grundlehner, B.; van de Molengraft, J.; Penders, J.; Gyselinckx, B. Body area network for monitoring autonomic nervous system responses. In *Proceedings of 3rd International Conference on Pervasive Computing Technologies for Healthcare*, London, UK, 1–3 April 2009; pp. 1–3.
- [20] Stoianov, I.; Nachman, L.; Madden S.; Tokmouline, T. PIPENET: A wireless sensor network for pipeline monitoring. In *Proceedings of the 6th International Conference on Information Processing in Sensor Networks (IPSN '07)*, Cambridge, MA, USA, 25–27 April 2007; pp. 264–273.
- [21] Ali Asghar Rahmani Hosseinabadi, Javad Vahidi, Behzad Saemi, Arun Kumar Sangaiah, Mohamed Elhoseny, Extended Genetic Algorithm for solving open-shop scheduling problem, *Soft Computing*, Volume 23, Issue 13, pp 5099–5116 (<https://doi.org/10.1007/s00500-018-3177-y>)
- [22] K. Shankar, Mohamed Elhoseny, E. Dhiravida chelvi, SK. Lakshmanprabu, Wanqing Wu, “An Efficient Optimal Key Based Chaos Function for Medical Image Security”, *IEEE Access*, Vol 6, No 1, Pages 77145-77154 (DOI: 10.1109/ACCESS.2018.2874026)
- [23] Muhammad Sajjad, Mansoor Nasir, Khan Muhammad, Siraj Khan, Zahoor Jan, Arun Kumar Sangaiah, Mohamed Elhoseny, Sung Wook Baik, "Raspberry Pi assisted face recognition framework for enhanced law-enforcement services in smart cities", *Future Generation Computer Systems*, Elsevier, 2018 (DOI: <https://doi.org/10.1016/j.future.2017.11.013>)
- [24] Alaa Tharwat, Hani Mahdi, Mohamed Elhoseny, Aboul Ella hassanien, Recognizing Human Activity in Mobile Crowdsensing Environment using Optimized k-NN Algorithm, *Expert Systems With Applications*, Volume 107, 1 October 2018, Pages 32-44 (<https://doi.org/10.1016/j.eswa.2018.04.017>)
- [25] Mohamed Abd El Aziz, Ahmed Monem Hemdan, Ahmed A. Ewees, Mohamed Elhoseny, Abdulaziz Shehab, Aboul Ella Hassanien, Shengwu Xiong, Prediction of Biochar Yield Using Adaptive Neuro-Fuzzy Inference System With Particle Swarm Optimization, In *2017 IEEE PES PowerAfrica Conference*, June 27-30, Accra-Ghana, IEEE, 2017, Pages 115-120 (DOI: 10.1109/PowerAfrica.2017.7991209)

- [26] Mohamed Elhoseny, Abdulaziz Shehab and Xiaohui Yuan, Optimizing Robot Path in Dynamic Environments Using Genetic Algorithm and Bezier Curve, *Journal of Intelligent & Fuzzy Systems*, vol. 33, no. 4, pp. 2305-2316, 2017, IOS-Press (DOI: 10.3233/JIFS-17348)
- [27] Xiaohui Yuan, Daniel Li, Deepankar Mohapatra, Mohamed Elhoseny, Automatic removal of complex shadows from indoor videos using transfer learning and dynamic thresholding", *Computers and Electrical Engineering*, Volume 70, August 2018, Pages 813-825 (<https://doi.org/10.1016/j.compeleceng.2017.12.026>)
- [28] Rizk M. Rizk-Allah, Aboul Ella Hassanien, Mohamed Elhoseny, A Multi-Objective Transportation Model under Neutrosophic Environment, *Computers and Electrical Engineering*, Volume 69, July 2018, Pages 705-719, (<https://doi.org/10.1016/j.compeleceng.2018.02.024>)
- [29] Shankar K, Mohamed Elhoseny, Lakshmanaprabu S K, Ilayaraja M, Vidhyavathi RM, Mohamed A. Elsoud, Majid Alkhabashi, Optimal feature level fusion based ANFIS classifier for brain MRI image classification, *Concurrency and Computation: Practice and Experience*, First Online: 27 August 2018, (DOI: <https://doi.org/10.1002/cpe.4887>)
- [30] K. Shankar, Mohamed Elhoseny, "Trust Based Cluster Head Election of Secure Message Transmission in MANET Using Multi Secure Protocol with TDES", *Journal for Universal Computer Science*, Vol. 25, No. 10, Page(s): 1221-1239, 2019.
- [31] Ashit Kumar Dutta, Mohamed Elhoseny, Vandna Dahiya, K. Shankar, "An efficient hierarchical clustering protocol for multihop Internet of vehicles communication", *Transactions on Emerging Telecommunications Technologies*, 2019. In Press. DOI: <https://doi.org/10.1002/ett.3690>