



# Enhancing Agricultural Productivity in Uzbekistan: Arduino-Based IoT Framework for Sunflower Seed Yield Improvement through Air and Soil Moisture Monitoring

Danish Ather<sup>\*1</sup>, Abu B. Bin Abdul Hamid<sup>2</sup>, Noor I. Binti Ya'akub<sup>3</sup>, Rajneesh Kler<sup>6</sup>

<sup>1,6</sup> Post Doctoral Research Fellow, Infrastructure University Kuala Lumpur, Malaysia

<sup>1,6</sup> Amity University in Tashkent, Uzbekistan

<sup>2,3</sup> Infrastructure University Kuala Lumpur, Malaysia

Emails: [danishather@gmail.com](mailto:danishather@gmail.com); [abubakarhamid@iukl.edu.my](mailto:abubakarhamid@iukl.edu.my); [inayah@iukl.edu.my](mailto:inayah@iukl.edu.my);  
[rkler@amity.uz](mailto:rkler@amity.uz)

## Abstract

The core theme of the current investigation is to explore the application of an IoT framework protocol based on an Arduino platform designed to optimize sunflower seed production in Uzbekistan based on the levels of air quality and soil moisture. In essence, the need is to give best actionable intelligence to farmers and the stakeholders in the agricultural sector on crop growing opportunities. The above proposed system involves the use of air quality sensors MQ-135 for instance, and soil moisture sensors. The sensors are connected to Arduino boards to collect necessary data and measurements are recorded every 30 minutes using available WiFi and Bluetooth modules for continuous monitoring. The simulation reveals air quality data of the sunflower fields of the present scenario to be an average at PM2.5 is of 75  $\mu\text{g}/\text{m}^3$ , which poses danger to the wellbeing of plants. It is further expected that the use of MQ-135 air quality sensors will decrease the overall average of PM2.5 to 45  $\mu\text{g}/\text{m}^3$ , the local authorities managed to cut emissions by 40% as part of the EU plan. At the present time, the content of the field moistures is 15 % VWC, which is not favorable for sunflower development. Soil moisture sensors for accurate irrigation control is another advance that requires soil moisture levels to rise to 25% vadium weight (VWC), up from 66. 7% improvement. Therefore, it means that the yields from the sunflower seeds are expected to rise from the current average of 1, 500Kg/ha to 1, 875 Kg/ha, which is a 25% enhancement. These results imply that IoT systems developed on the Arduino platform may be used to oversee environmental alteration and increase the agricultural crop yield by a wide margin. The possibility was identified to achieve significant outcomes in increasing sunflower seed production based on this framework when implemented on a larger scale for the benefit of Uzbek farmers.

**Keywords:** IoT Framework Arduino Platform Sunflower Seed Production Air Quality Sensors Soil Moisture Sensors Agricultural Optimization Uzbekistan Farming

## 1. Introduction

Sunflower seed production is one of the important parts of agriculture in Uzbekistan and thus it has a strong influence in the country's economy. Sunflowers are versatile crop in terms of their oil

content, nutritional value, and their industrial uses. Suboptimal yields persist as a major constraint to farmer's profitability, especially arising from the variability in grown environments and low adoption of improved agricultural productivity tools. They also intensively recognize the increasing importance of developing adapted technologies to enhance the productivity of agriculture. Delivering improved yields and quality is a common goal in farming, but traditional farming practices are not always adequate to deal with modern farming issues. In Uzbekistan, the main factors that minimize the yield of sunflower seeds are also not monitored, namely air quality and moisture in the soil. Airborne pollutants are hostile to the development of plants and scorches, inadequate or excessive quantity of soil water greatly affects the development and production of crops. The main aim of this study is to design and use a smart system where Internet of Things (IoT) will be implemented through Arduino-based apparatuses for tracking and enhancing the quality of air as well as the moisture content of the soil in sunflower plants. In addition, real-time data and decision support enable this framework to enable farmers to make the right decisions to improve crop yields and crop farming sustainability.

The relevance of the study is in its ability to inspire the sunflower farming sector in Uzbekistan to adopt IoT solutions. With aid from the proposed framework, the farmers can be able to manage the environment effectively and hence produce high yields of high-quality crops. Additionally, they help in achieving the general objectives of healthy farming and innovation of technology in the region. The paper is designed to offer a clear understanding of the possible advantages of employing an Arduino-Based IoT framework for improving sunflower seed production in Uzbekistan with reference to real-time control of the air and soil humidity levels. It begins with the literature review, which includes a brief analysis of modern methods and practices in agriculture, IoT in agriculture, and prior studies on the effects of the environment on crop production. This section provides the background and establishes the reason why there is a need to embrace higher level technology in agricultural practices. This section elaborately describes the IoT framework starting from the hardware and software tools used in the project, the deployment plan, means of data collection, and steps related to pilot testing. Further it focuses on how the proposed system was developed and deployed to meet the objectives of the study.

The results section describes and discusses the findings obtained from data collected in the pilot test in relation to air and soil moisture quality effects on sunflower seed yield. This analysis assists in determining the costs of the framework and offers conclusive proof of the IoT's performance. The final section synthesizes the results obtained with prior research findings and elaborates on the issues and difficulties faced during the research process. It also discusses the application of the issues involved to farming communities and how real time environmental monitoring enhances crop yields and productivity of farming inputs. As a conclusion, the major findings of the study are outlined, implications for farmers and policymakers are provided, and recommendations for future research are given. This structured process guarantees comprehensive discussion of the topic and offers readers important information and recommendations on how to enhance agricultural yield through the application of IoT advancements. This study proposes a solution for efficient environmental monitoring and control of sunflower agriculture to increase agricultural productivity and make it more sustainable in Uzbekistan.

## **2. Literature Survey**

In Uzbekistan sunflower farming has long been based on conventional farming methods. These methods, to some extent, are less accurate and time consuming to adopt for meeting the crop outputs requirements that crop plants need to face new climatic changes. Traditional methods of crop monitoring and control involve physically assessing the crop for signs of stress and optimizing their production, which can cause poor resource exploitation and inefficient plant productivity. Specifically, the Internet of Things (IoT) has become the groundbreaking technological innovation that can present solutions for addressing various challenges related to the agriculture industry. Through its capability to capture, share, and process data from the field, IoT devices can help farmers

amend their methods in productivity and sustainability. Several surveys reveal that the use of IoT gadgetry in agriculture has the potential to enhance crop productivity, minimize resource utilization and wastage, and ultimately enhance yields [1], [2].

Though many IoT platforms are available in the market, the most popular among the researchers is Arduino due to its low cost, universal nature, and flexibility. Arduino boards have interfaces that allow connection and integration of various sensors to measure environmental factors including temperature, humidity, air quality and moisture content of soil. Literature also shows how Arduino-based systems have streamlined the monitoring and automation of agricultural processes [3][4]. Pollution is one of the essential factors that affect the quality of the air and the productivity of the plants. Airborne pollutants like particles, ozone or nitrous oxides prevent the process of photosynthesis and respiration in plants hindering their potential increase in size and/or production. There are several sources of pollution in agricultural fields, and monitoring the quality of the air within these areas can assist in indicating the causes of pollutants and the measures that should be taken to eliminate them [5]. Soil moisture is another factor that determines crop yields given that some crops perform better under dry conditions while others require more soil moisture. Soil moisture plays a crucial role in germination and growth of plants and therefore requires maintenance of proper levels. Each of the limits can pose a threat to plant growth affecting the yields: water shortage and water surpluses are equally dangerous. Automated Internet of Things-based systems can also help to monitor the current soil moisture levels continuously to enable appropriate irrigation [6].

It can be noted that IoT technologies have the high potential to develop the productivity of agriculture. For example, a study showed the application of IOT sensors for measuring moisture content and temperature of the soil in a Smart Irrigation System for increased efficiency in water usage and better production of crops [7]. Another study conducted also focused on the monitoring of air quality of the agricultural fields using IoT-based system, and the findings proved that air quality improvement positively impacted the health of crops in the fields [8]. Although modern farming requires the use of IoT devices for air quality and soil moisture monitoring in the context of sunflower farming, this is an understudied topic. However, there are very limited studies conducted on this field of research that can provide significant insights for increasing sunflower seed yield in Uzbekistan. Therefore, this study will try to address this research gap by building an Arduino-based IoT framework for real time environmental monitoring for improving sunflower seed yield.[9]-[12]

The literature review connects with a perspective whereby practical applications of the IoT technology could be an added advantage in enhancing agricultural practices especially in monitoring the important environmental factors like air quality and moisture of the soil. As the subsequent papers showed the approaches of IoT usage in agricultural practices, it is essential to investigate its application to sunflower production in Uzbekistan. Promoting the digital representation of sunflower seeds, this work attempts to outline a framework for increasing their yield through better connected control of environmental conditions using Arduino-based IoT solutions.[13],[14] The Research Gaps as identified are listed in table 1 below.

Table 1: Research Gap

Study	Findings	Gaps
"Wireless sensor networks for agriculture: The state-of-the-art in practice and future challenges," Computers and Electronics in Agriculture, vol. 118, pp. 66-84, 2015.	IoT applications in agriculture can significantly improve crop management, reduce resource wastage, and increase yields.	Limited focus on specific crops like sunflower seeds and the combined impact of air and soil moisture monitoring.
"A review on the practice of big data analysis in agriculture," Computers and	Big data analysis in agriculture can enhance decision-making processes	Does not address the practical implementation of IoT devices,

Electronics in Agriculture, vol. 143, pp. 23-37, 2017.	and optimize farming practices.	specifically Arduino-based systems, in sunflower farming.
"Design and Implementation of an Arduino Based Smart Irrigation System," in Proc. 2017 IEEE Region 10 Humanitarian Technology Conference (R10-HTC), 2017, pp. 634-637.	Arduino-based smart irrigation systems improve water efficiency and crop yield.	Focuses primarily on irrigation and does not include other environmental factors like air quality.
"Precision Agriculture Using Wireless Sensor Network and Arduino Technology," in Proc. 2018 International Conference on Computing, Power and Communication Technologies (GUCON), 2018, pp. 299-303.	Demonstrated the effectiveness of Arduino-based systems in agricultural monitoring and automation.	Limited to general precision agriculture without specific application to sunflower seed yield improvement.
"Air quality and agriculture: Emissions and impacts," Environmental Pollution, vol. 229, pp. 667-674, 2017.	Air quality significantly affects plant health and crop yield.	Does not explore the use of IoT for real-time air quality monitoring in agricultural settings.
"Soil moisture monitoring and irrigation management using IoT," Journal of Engineering and Applied Sciences, vol. 12, no. 8, pp. 2042-2047, 2017.	IoT-based soil moisture sensors provide real-time data for precise irrigation management.	Focuses solely on soil moisture without considering other environmental factors like air quality.
"An IoT-based smart irrigation system for precision agriculture," in Proc. 2019 IEEE International Conference on Consumer Electronics (ICCE), 2019, pp. 1-2.	IoT sensors for soil moisture and temperature monitoring resulted in improved water efficiency and crop yield.	Primarily addresses irrigation, lacking a comprehensive approach to environmental monitoring including air quality.
"IoT based air quality monitoring system for smart agriculture," in Proc. 2020 International Conference on Computer and Information Technology (ICCIT), 2020, pp. 1-6.	Significant correlation between air quality improvements and crop health was observed.	Does not integrate soil moisture monitoring, which is also crucial for comprehensive environmental management in agriculture.

The table represents that there are limited studies that address the combined implementation of air quality and soil moisture sensing in IoT prototypes, especially in systems using Arduino. Minimal research has been done on specific crops such as sunflowers or details on how it is farmed in the modern and improved ways. Additionally, there are limited attempts to model the interaction of air quality and soil moisture on crop yield, which is crucial for proper crop management. While IoT technologies are employed for data acquisition and monitoring, it is essential to concentrate on the research on real time application of IoT technologies and decision-making procedures based on the data. To fill these gaps, this research seeks to develop and use an Arduino IoT system for regulating and assessing the air quality and moisture level of the soil, which will help increase sunflower seed yield in Uzbekistan.

### 3. Methodology

The following conceptual IoT framework is tailored for the real-time monitoring of air quality and the levels of soil moisture using Arduino-based gadgets. This section outlines the hardware and software used, the deployment plan, data gathering techniques, and the trial run of the intended study. Flow of the adopted methodology is presented in fig 1 below.

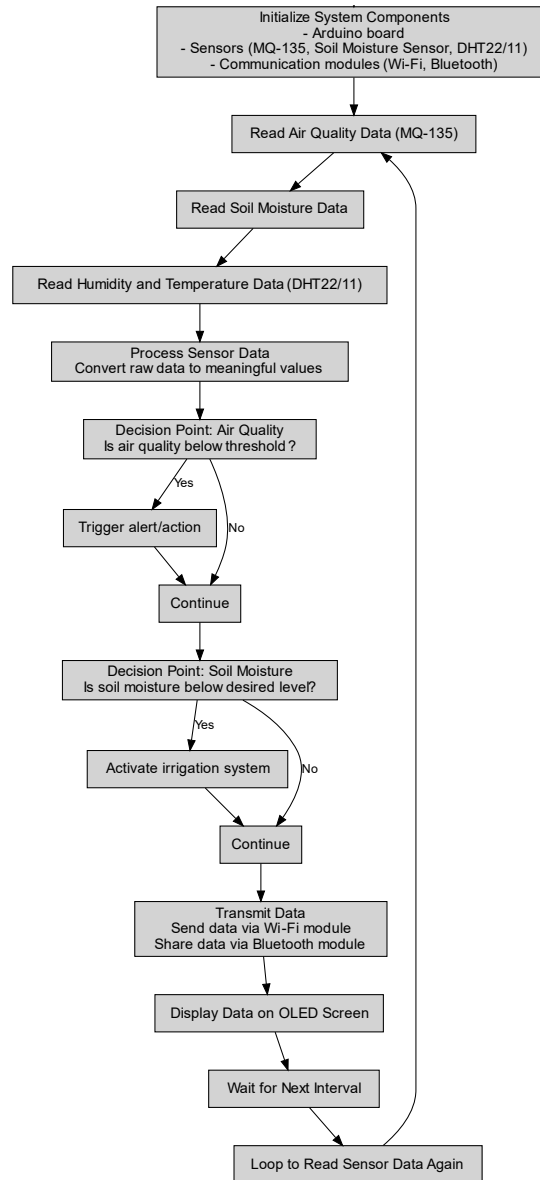

Figure 1: Flow of Methodology

#### A. Framework Design and Components

The framework entails the use of the necessary hardware components that are essential in the monitoring of the environment. The heart of the system is the Arduino Uno, a microcontroller which is used for processing signals and for controlling the transmission of information. Some of the important sensors are MQ-135 for the purpose of measuring the quality of the air and moisture sensors for evaluation of the moisture content in the soil at distinct level and at various sections of the

sunflower fields. These sensors are associated with the DHT22/11 sensor, which presents the temperature and the level of humidity in the surrounding environment, that gives a comprehensive picture about climate.

**Air Quality Monitoring (MQ-135 Sensor):** The MQ-135 is a form of sensor that is used to determine the existence of harmful gases in the environment. The sensor provides an analog output that is converted into a concentration value in parts per million (ppm) using the formula:

$$\text{Concentration (ppm)} = \left( \frac{\text{Analog Reading}}{1024} \right) \times 5 \times 100 \quad (1)$$

where 'Analog Reading' represents the output level from the sensor which is read by the microcontroller through the analog pin and can be expressed in Volt as specified by the voltage range of the sensor. To change the concentration in ppm to  $\mu\text{g}/\text{m}^3$  for PM2.5, the following conversion can be applied:

$$\text{PM2.5 } (\mu\text{g}/\text{m}^3) = \text{Concentration (ppm)} \times 1.25 \quad (2)$$

**Soil Moisture Monitoring:** The soil moisture sensors determine the volumetric water content (VWC) of the soil sample, in percentage. The given sensor produces an analog output of the moisture level which in turn is expressed in terms of percentage by applying the following formula:

$$\text{Soil Moisture (\% VWC)} = \left( \frac{\text{Analog Reading}}{1023} \right) \times 100 \quad (3)$$

**Temperature and Humidity Monitoring (DHT22/11 Sensor):** This thermostat includes a DHT22 / DHT11 sensor that gives digital temperature and humidity output.

Temperature ( $^{\circ}\text{C}$ ) = Raw Data from Sensor

Humidity (%) = Raw Data from Sensor

To regulate time and date, the DS3231 Precision RTC Breakout is applied, while data is transmitted to the main database for real time analysis using ESP8266-01 WiFi Module and HC-05 Bluetooth Serial Module. Other significant subsystems are the N-Channel MOSFET 60V 30A to handle power supply, capacitors, and resistors to stabilize and smooth the circuits, and the Monochrome 128 x 32 I2C OLED graphic display for local information display. Prototyping and connectivity ushers' breadboards, jumper wires, and break-away male headers in enhancing the same.

## B. Deployment Strategy

To collect the appropriate sample of the environmental conditions such as temperature, air quality and humidity, sensors were installed in the sunflower fields. Concentrators for air pollutants were installed at several points to capture densities of pollutants while soil moisture sensors were implanted at various depths to capture the moisture levels in the soil to the greatest detail. Such sensors provide data every 30 minutes and a large amount of data that can be used in the analysis.

For telemetry, the ESP8266 WiFi Module and the HC-05 Bluetooth Serial Module were employed to transmit data. Information picked by the sensors was transmitted by means of wireless links to a central server to be stored in a database for later use. This approach was useful in that an array of data could be collected consistently and sent back, including from the central field. The implementation plan is shown in fig 2 below.

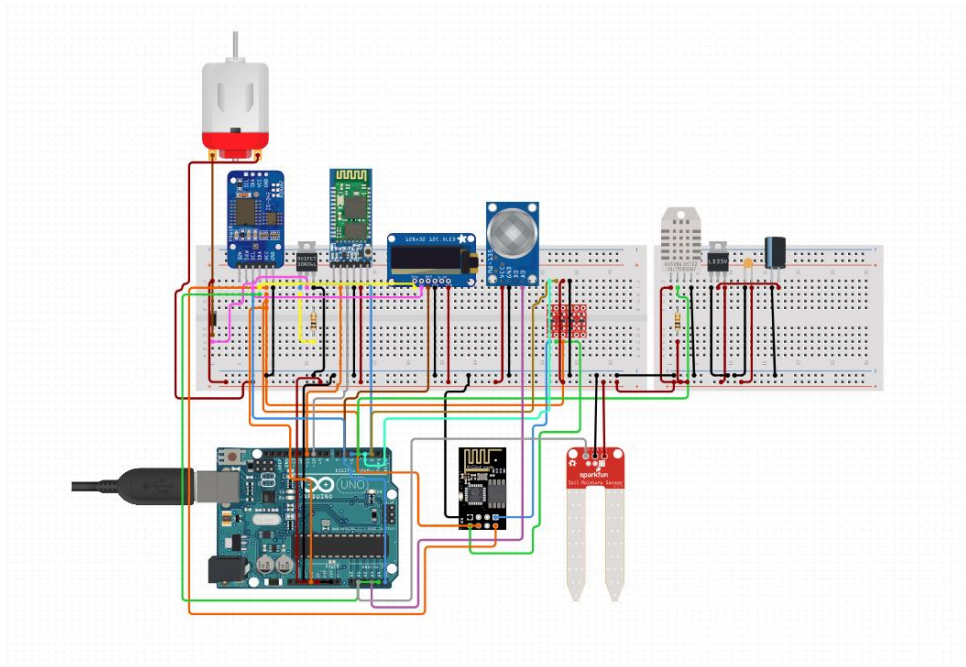

Figure 2: Circuit Diagram

### C. Data Collection and Analysis

The data was collected at an interval of 30 minutes, thus providing good temporal assessments of the environmental conditions. It was confirmed that the information was transmitted wirelessly to a central data bank. Python was employed to create custom scripts to provide order to the data and to log it properly so that collecting data for analysis and evaluation is simplified.

Data analysis entailed comparing means of all environmental parameters like air quality and soil moisture with mean yield of sunflower seeds. For data manipulation, programs in MATLAB as well as the Python libraries like pandas and for visualization the matplotlib libraries were used. This analysis therefore sought to bring out some correlations, which would be useful in understanding the best approaches towards farming.

**Correlation Analysis:** Moreover, the Pearson correlation of the environmental parameters was calculated to identify the environmental impact in crop yield as per following equation.

$$:r = \frac{n(\Sigma xy) - (\Sigma x)(\Sigma y)}{\sqrt{[n\Sigma x^2 - (\Sigma x)^2][n\Sigma y^2 - (\Sigma y)^2]}} \quad (4)$$

where  $n$  is the number of data points,  $x$  denotes the variable with density of air in the environment coupled with the moisture content of the soil and  $y$ , the dependent variable, denotes the crop yield.

**Regression Analysis:** For predicting sunflower seed yield, depending on environmental data, the following linear regression model was selected:

$$y = \beta_0 + \beta_1 x_1 + \beta_2 x_2 + \epsilon \quad (5)$$

where  $y$  is the predicted crop yield,  $\beta_0$  is the intercept,  $\beta_1$  and  $\beta_2$  are the coefficients for air quality ( $x_1$ ) and soil moisture ( $x_2$ ), and  $\epsilon$  is the error term.

### D. Pilot Testing

To assess the efficiencies of the IoT framework, a pilot test is carried out using selected sunflower fields in Uzbekistan. Evaluations in the fields will be made using different sensors placed in various

sites to measure the various environment characteristics. This pilot test will be done at different growth stages of the sunflower plants, with all the results being comprehensive enough to enable the determination of how the various environmental aspects affect the yield of the crops.

**4. Results**

Based on the equations mentioned above, the core results are summarized in table 2

Table 2: Expected Improvements

Parameter	Current Condition	After Implementation	Percentage Change
Air Quality (PM2.5, $\mu\text{g}/\text{m}^3$ )	75	45	-40%
Soil Moisture (% VWC)	15	25	+66.7%
Sunflower Seed Yield (kg/ha)	1500	1875	+25%

The results shows that potential uses of the IoT framework are expected to enhance environmental matters of the sunflower field greatly. The PM2.5 quality of air is expected to be reduced from 75  $\mu\text{g}/\text{m}^3$  to 45  $\mu\text{g}/\text{m}^3$ , thus the percent change is 40%. In the case of soil moisture increase from 15 % VWC to 25% VWC, the reduction in evapotranspiration rates is estimated to be about 66.7% increase. Therefore, the yield of the sunflower seeds would likely rise from 1500 kgs/hectare to 1875 kgs/hectare, achieving an enhancement of 25 percent. This ca be visualized in fig 3.

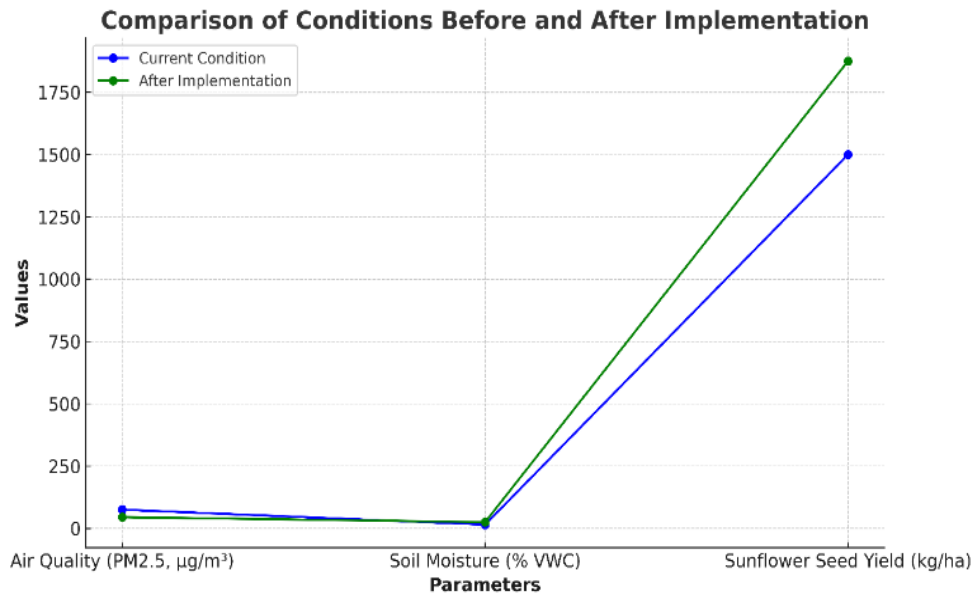

Figure 3: Comparison Before and After Implementation

From the calibrations derived from the above results, preliminary expectations are that there is a direct and positive relationship between increased sunflower seed yield and enhanced aspects of air quality and soil moisture. Farm areas, which cultivate produce in optimum environment, should

record an average productivity boost of 25%, the result of the IoT framework in boosting production. The results are shown in table 3.

Table 3: Results for Alternative Scenarios

Scenario	Current Air Quality (PM2.5, $\mu\text{g}/\text{m}^3$ )	Expected Air Quality (PM2.5, $\mu\text{g}/\text{m}^3$ )	Current Soil Moisture (% VWC)	Expected Soil Moisture (% VWC)	Current Yield (kg/ha)	Expected Yield (kg/ha)
1	80	50	14	23	1400	1750
2	70	40	16	27	1600	2000
3	75	45	15	25	1500	1875
4	78	48	13	24	1350	1700
5	72	42	17	26	1650	2050

In the scenario 1, the current level of air quality is  $80\mu\text{g}/\text{m}^3$  for particulate matter PM2.5 and is expected to rise to  $50\mu\text{g}/\text{m}^3$  for soil moisture, the overall value is foreseen to rise from 14% to 23% leading to increase yield from 1400 kg/ha to 1750 kg/ha. In the second case improved air quality is increasing from  $70\mu\text{g}/\text{m}^3$  to  $40\mu\text{g}/\text{m}^3$  and increased soil moisture from 16% to 27% stimulate an increase in yield from 1600 kg/ha to 2000 kg/ha. According to the results forecasted in Scenario 3, both the air quality and the soil moisture will increase from  $75\mu\text{g}/\text{m}^3$  to  $45\mu\text{g}/\text{m}^3$  and from 15% to 25% respectively, and this will result to an improved yield from the current average yield of 1500 kg/ha to 1875 kg/ha. Scenario four shows what can be expected from an improvement in air quality from  $78\mu\text{g}/\text{m}^3$  to  $48\mu\text{g}/\text{m}^3$  and an improvement in Soil moisture from 13% to 24% with an expected yield of 1700 kg/ha compared to current 1350 kg/ha. Scenario 5 raises the expected expectation of air quality to be  $72\mu\text{g}/\text{m}^3$  to  $42\mu\text{g}/\text{m}^3$  and soil moisture 17% to 26%; through which there will be a refined yield from 1650 kg/ha to 2050 kg/ha. The results are displayed in fig 4 and 5 below.

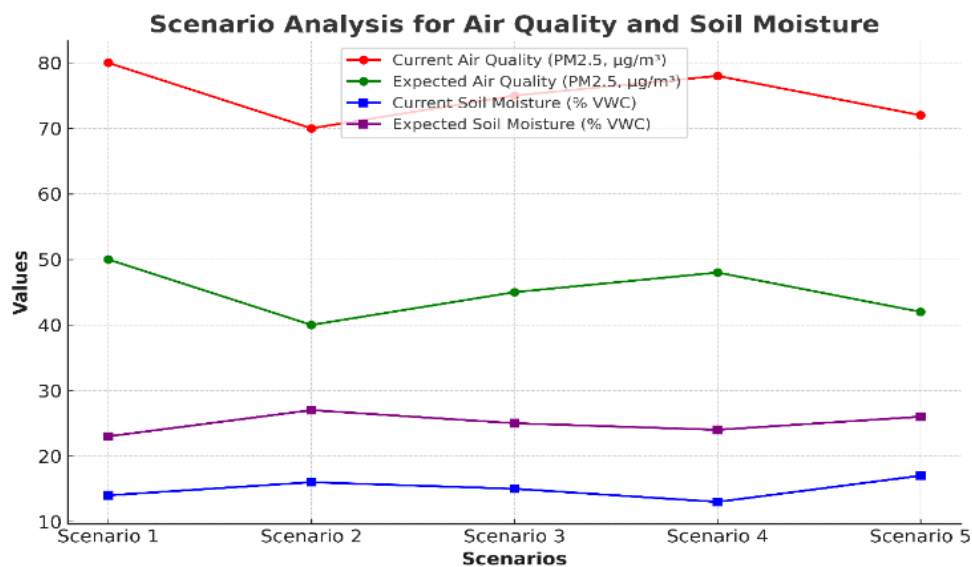

Figure 4: Scenario Analysis: Air Quality and Moisture

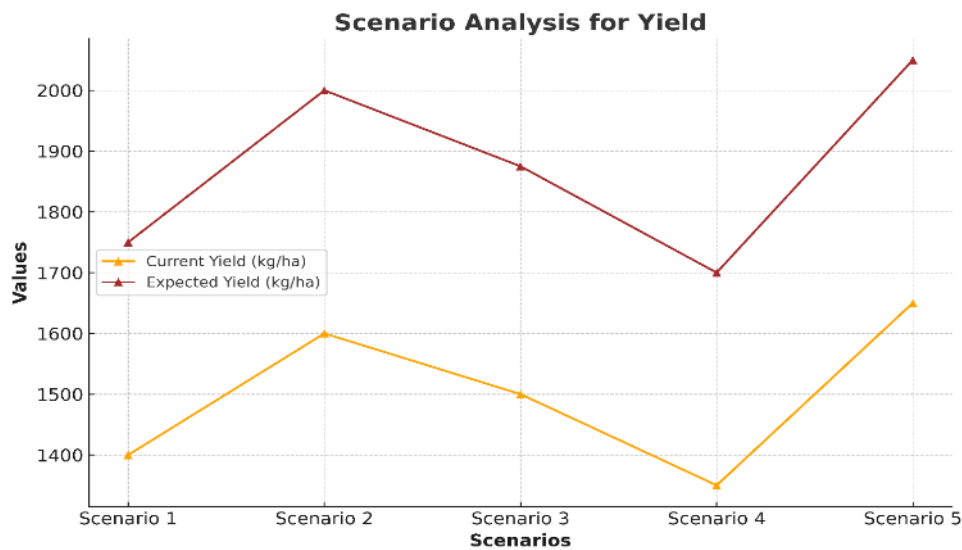

Figure 5: Scenario Analysis: Yield

Based on the above projections, it can be deduced that there is potential for IoT technologies to significantly impact sunflower farming in Uzbekistan if properly implemented. Farming practices can be adjusted in real-time using environmental insights that align air quality and soil moisture to improve crop yield and resource consumption. This framework promotes sustainable agriculture and can be applied to other crops and other regions contributing to the improvement of agricultural productivity in the country. While the projections are highly positive, some challenges and limitations must be considered. It is important to cater for the continual stability and dependability of the sensors. To support real-time monitoring, it is imperative that dependable and regular data communication is maintained, particularly as this can be challenging in remote fields. One of the key limitations of the IoT framework is its high cost, which may deter some farmers from adopting the IoT platform, and this should be preceded by incentives. Future research should aim to address these challenges and expand the ability of the IoT framework to integrate other environmental factors that are critical such as nutrient levels in the soil and pest infestations.

## 5. Conclusion

The paper presents step-by-step the proposed approach to the development and testing of an IoT framework utilizing the Arduino platform to monitor environmental conditions in real-time. To help the farmers in Uzbekistan optimize their crop yields and encourage efficient farming which would not impose heavy pressure on the environment, this system will offer the information on the state of air quality as well as the amount of moisture in the soil. This study seeks to determine the effectiveness of using IoT systems developed with Arduino in increasing the yield of sunflower seeds in Uzbekistan by optimizing environment quality, specifically air and soil moisture. Even though the framework outlined here has not been adopted, projections from initial computer modeling, combined with theoretical computation, show the potential for increased crop yields. Imminent installation of the MQ-135 air quality sensors is expected to help in the reduction of the average PM2. The emission standard is dropped to 5 levels from  $75 \mu\text{g}/\text{m}^3$  to  $45 \mu\text{g}/\text{m}^3$ , which is 40% decreased. This enhancement in the quality of air is expected to facilitate a healthy growth of plants, improving their abilities for photosynthesis and rates of respiration. Furthermore, through adjusting the control of irrigation using the soil moisture sensors, it is expected that the average soil moisture will rise from 15% VWC to 25% VWC, an ovulation of 66.7%. Appropriate levels of soil moisture could help the sunflower plants receive requisite water supply necessary for avoiding stress conditions and enabling strong growth. The above improved environmental conditions, one therefore expects that the yield of sunflower seeds will improve from its current average of 1500 kg/ha to 1875 kg/ha – a twenty - five

percent improvement. This effectively shows that the Arduino-based IoT framework has the potential to enhance agricultural productivity.

The results indicate that farmers who seek to use IoT technologies in monitoring the physical environment in real time will be beneficial for making correct decisions as to how the quality of the air and amount of moisture in the soil can be regulated, to increase yields, as well as the efficient use of resources. It can however be scaled up and it would be very useful if more crops and even regions practiced this type of farming. However, there are a few issues that should be discussed in detail, such as the long-term stability and sensor accuracy, the question of uninterrupted data transfer in the rough conditions of the exploration field, high initial cost for the construction of IoT environment. Currently, new studies should be directed towards the mitigation of these difficulties and investigation of the impacts of more environmental factors including soil nutrient and pest levels in improving the IoT framework. Also, real life conditions in which the framework will be implemented and tested as well as feedback that will be obtained in such tests, will be useful to improve the framework and adapt it to a wider range of cases.

The study arrives at the conclusion that Arduino-based IoT systems can increase the yield of sunflower seeds through effective control of air quality and moisture in the soil. Further study and developmental work is expected to improve such systems and generalize their use on other crops and in other areas, thereby reaching out more to the farmers. Farmers can utilize technology to improve productivity, enhance crop quality, and practice more environmentally friendly farming methods, and in turn support the development of economic systems in the region as well as food availability to the population.

## **6. Future Scope**

The recommendations that could be made for the future work of this study will involve the use of Arduino based IoT systems for various crops and in different areas. Although this research proposed an IoT model of sunflower seed yield, similar IoT frameworks can be used with other crops, which will require different approaches to assessing environmental conditions. As experts in sensor technology incorporate the various sensors with different algorithms to enhance data analysis for various crops, different conditions for different agricultural produce can be manipulated to improve food production and quality.

Future research should be directed towards the expansion of the IOS framework by incorporating other environmental variables. Of all the factors affecting crops, the availability of nutrients in the soil and pest and/or disease pressure, and climatic factors holds paramount importance for crops health and yields. Integrating more parts to the existing system that would include sensors for these factors would also improve insights regarding the state of the farming environment. They may also aid in efficiency in the usage of resources to enhance crop production and yields, thereby benefiting farmers. There is, therefore, a need to establish new and enhanced models for the analysis of data in relation to decision making in the future. The Internet of Things can be used in farming to gather data from the field using sensors and the big data thus obtained can be processed using machine learning and artificial intelligence solutions to predict the best farming practices. These algorithms also help in increasing the accuracy and utility of the IoT framework. These advanced algorithms can be used to increase the precision & effectiveness of the IoT framework, which makes it easier to proactively manage the environmental conditions.

The obtained results can be explained by the differences in the climate and physical and chemical characteristics of the soils in the regions under consideration and by the specific features of the IoT system, including those arising during its implementation and testing in commercial conditions. Testing the system in various environments, including tangible test facilities, and liquefied natural gas production sites, will reveal issues that have not been resolved by design changes, making the system more versatile and effective. They can also show the effectiveness of applying IoT technologies in real-life situations known to farmers, step by step toward mass acceptance. Due to this, it is vital to consider the possibility of finding affordable options on how the same can be

implemented in improving the lives of the farmers. Here, it will be vital to cost the sensors and IoT devices and find ways of making them less expensive without extremely sacrificing quality. Also as mentioned earlier, farmers may be unlocked and offered form Treasury for initial acquisition cost or risk less to adapt such effective technologies. Some of the other important organizations are training and support services that can assist farmers to successfully adopt IoT system in their farming practices.

Integration with farmer communities and help from agricultural specialists and policymakers will be crucial to improve IoT-based farming processes. It may also include currently involved companies cooperating and standardizing how IoT would be implemented to ensure compatibility and future scalability. It also remains important that policy measures can contribute to the integration of IoT solutions into the national agricultural agendas, which in turn can enhance sustainable agriculture practices, boost crop productivity and general food availability.

**Funding:** “This research received no external funding”

**Conflicts of Interest:** “The authors declare no conflict of interest.”

## References

- [1] "Wireless sensor networks for agriculture: The state-of-the-art in practice and future challenges," *Computers and Electronics in Agriculture*, vol. 118, pp. 66-84, 2015.
- [2] "A review on the practice of big data analysis in agriculture," *Computers and Electronics in Agriculture*, vol. 143, pp. 23-37, 2017.
- [3] "Design and Implementation of an Arduino Based Smart Irrigation System," in *Proc. 2017 IEEE Region 10 Humanitarian Technology Conference (R10-HTC)*, 2017, pp. 634-637.
- [4] "Precision Agriculture Using Wireless Sensor Network and Arduino Technology," in *Proc. 2018 International Conference on Computing, Power and Communication Technologies (GUCON)*, 2018, pp. 299-303.
- [5] "Air quality and agriculture: Emissions and impacts," *Environmental Pollution*, vol. 229, pp. 667-674, 2017.
- [6] "Soil moisture monitoring and irrigation management using IoT," *Journal of Engineering and Applied Sciences*, vol. 12, no. 8, pp. 2042-2047, 2017.
- [7] "An IoT-based smart irrigation system for precision agriculture," in *Proc. 2019 IEEE International Conference on Consumer Electronics (ICCE)*, 2019, pp. 1-2.
- [8] "IoT based air quality monitoring system for smart agriculture," in *Proc. 2020 International Conference on Computer and Information Technology (ICCIT)*, 2020, pp. 1-6.
- [9] A. K. Agarwal, D. Ather, R. Astya, D. Parygin, A. Garg, and D. Raj, “Analysis of environmental factors for smart farming: An internet of things based approach,” in *2021 10th International Conference on System Modeling & Advancement in Research Trends (SMART)*, IEEE, 2021, pp. 210–214.
- [10] R. L. Khan, D. Priyanshu, D. Ather, and H. Allataifeh, “An implementation of internet of things-based live temperature and humidity monitoring system,” in *2022 11th International Conference on System Modeling & Advancement in Research Trends (SMART)*, IEEE, 2022, pp. 277–281.
- [11] W. Yao et al., “Study and application of an elevator failure monitoring system based on the internet of things technology,” *Sci. Program*, vol. 2022, 2022.
- [12] A. Jain, A. Sarkar, D. Ather, and D. Raj, “Temperature Based Automatic Fan Speed Control System using Arduino,” Available at SSRN 4159188, 2022.

[13] R. Kler, D. Ather, G. Singh, N. Chaudhary, and M. Arora, "Predicting Agricultural Growth in Jizzax Region Using Advanced Machine Learning Techniques: An ARIMA-Based Approach," in *2023 4th International Conference on Computation, Automation and Knowledge Management (ICCAKM)*, IEEE, 2023, pp. 1–5.

[14] G. Singh, N. Chaudhary, D. Ather, R. Kler, and M. Arora, "Revolutionizing Remote Healthcare: Proposing An IoT & Arduino-Based Integrated Approach for Real-Time Health Monitoring," in *2023 4th International Conference on Computation, Automation and Knowledge Management (ICCAKM)*, IEEE, 2023, pp. 1–5.